

FIRE INVESTIGATOR

SKILLS MANUAL

CHAPTER FIVE

NFPA 1033 – 2014 Edition

Effective January 1, 2015



Texas Commission on Fire Protection
P.O. Box 2286 Austin, Texas 78768-2286 (512) 936-3838

INSTRUCTION SHEET

FIRE INVESTIGATOR PERFORMANCE SKILLS

Format

Each skill contains its own skill sheet, is evaluated independently, and is based on the JPRs in National Fire Protection Association (NFPA) 1033, *Standard for Professional Qualifications for Fire Investigator*, 2014 edition.

For skill sheets that do not contain time constraints, the Course Instructor should specify time constraints as necessary.

Scoring Method

The scoring method is satisfactory (S) or unsatisfactory (U) for each step of the skill objective, and a Pass or Fail for each individual skill section. In order to successfully pass an individual skill section, the Fire Investigator candidate must receive satisfactory scores in all the steps of the skill objective. In order to receive an overall Pass on the skill sheet, the Fire Investigator candidate must receive a passing score for all individual skill sections.

Any unsatisfactory or individual skill failure shall require the examiner to explain the reason for the failure in written form in the comments section of the skill sheet.

Preparation and Equipment

For optimal learning, scenario based training and role-playing is recommended; however, based on departmental needs certain activities may be simulated by other means.

Fire Investigator Skills

Subject	Skill No.	Functional Name	NFPA 1033 #
Scene Examination	1	Securing the Fire Ground	4.2.1
Scene Examination	2	Conducting an Exterior Survey	4.2.2
Scene Examination	3	Conducting an Interior Survey	4.2.3
Scene Examination	4	Interpret Fire Patterns in a Vehicle	4.2.4
Scene Examination	5	Interpret and Analyze Fire Patterns	4.2.4, 4.2.5
Scene Examination	6	Examining and Removing Fire Debris	4.2.6, 4.2.9
Scene Examination	7	Reconstructing the Area of Origin	4.2.7
Scene Examination	8	Inspecting the Performance of Building Systems	4.2.8
Documenting the Scene	9	Diagramming the Scene	4.3.1
Documenting the Scene	10	Photographically Documenting the Scene	4.3.2
Documenting the Scene	11	Constructing Investigative Notes	4.3.3
Evidence Collection/Preservation	12	Utilizing Proper Procedures for Managing Victims and Fatalities	4.4.1, 4.4.2, 4.4.3
Evidence Collection/Preservation	13	Maintaining a Chain of Custody	4.4.4
Evidence Collection/Preservation	14	Disposing of Evidence	4.4.5
Interview	15	Developing an Interview Plan	4.5.1
Interview	16	Conducting Interviews	4.5.2
Interview	17	Evaluating Interview Information	4.5.3
Post-Incident Investigation	18	Gathering Reports and Records	4.6.1
Post-Incident Investigation	19	Evaluating the Investigative File	4.6.2
Post-Incident Investigation	20	Coordinating Expert Resources	4.6.3
Post-Incident Investigation	21	Establishing Evidence as to Motive and/or Opportunity - Incendiary Fire	4.6.4
Post-Incident Investigation	22	Formulating an Opinion of the Person(s) and/or Product(s) Responsible for the Fire	4.6.5
Presentations	23	Preparing a Written Investigation Report	4.7.1
Presentations	24	Verbally Expressing Investigative Findings	4.7.2
Presentations	25	Testifying During Legal Proceedings	4.7.3

Fire Investigator Skills Equipment List

Fire ground (actual or simulated)

- Structure
- Video
- PowerPoint
- Slides
- With evidence of an explosion
- Simulated victim or fatality
- Vehicle
- Building systems

Six items of potential evidence

Burned items

Protective clothing (Appropriate safety equipment)

- Boots
- Gloves
- Hard hat
- Safety glasses
- SCBA (if IDLH atmosphere)

Standard equipment and tools

Model evidence policy

Marking devices

Evidence collection containers

Evidence tags or labels

Chain of custody forms

Evidence disposal forms

Incendiary investigation file including:

- Incident information
- Interview Information
- Photos
- Suppression report
- Conflicting information
- Expert witness backgrounds
- Competencies
- Fee schedules
- Authorization from the prosecutor to include the candidate's opinion in the report

Witness statements

Standard crime lab analysis form

Floor plan map

Pre fire plans

Inspection reports

Fire report (TEXFIRS)

Fire scene tape

Measuring device

Pencil/pen

Note pad

Photo log

Camera with flash, and accessories

- 35 mm
- Digital
- Film

Interview room setting

Interview forms

Interview transcripts

DOT *Emergency Response Guidebook*, current edition

Various placards

Scenario involving identified hazardous materials

Additional personnel if needed

TEXAS COMMISSION ON FIRE PROTECTION
Fire Investigator
Performance Standards Evaluation

Skill Number 1
Securing the Fire Ground

Subject: Scene Examination

NFPA 1033, 2014 edition, 4.2.1

Fire Investigator

OBJECTIVE

Secure the fire ground, given marking devices, sufficient personnel, and special tools and equipment, so that unauthorized persons can recognize the perimeters of the investigative scene and are kept from restricted areas and all evidence or potential evidence is protected from damage or destruction. (4.2.1)

INSTRUCTIONS - procedures for achieving the objective

The Investigator candidate shall secure the fire ground to protect evidence and restrict access.

EXAMINER'S NOTE

The Investigator candidate will not be allowed to review the performance steps at the time of testing.

The fire ground scene may be physically simulated; however, the investigator candidate must perform each step of the required skill in the presence of the field examiner.

PREPARATION & EQUIPMENT

Fire ground (actual or simulated)
Marking devices
Appropriate safety equipment

Reprinted with permission from NFPA 1033, *Professional Qualifications for Fire Investigator*, Copyright ©2013, National Fire Protection Association, Quincy, MA 02169. This reprinted material is not the complete and official position of the National Fire Protection Association on the referenced subject which is represented only by the standard in its entirety.

TEXAS COMMISSION ON FIRE PROTECTION
Fire Investigator
Performance Standards Evaluation

Candidate: _____ Notes: _____

Training Provider: _____

Test Site: _____

Examiner: _____

Fire Investigator	<u>TEST</u>		<u>RETEST</u>	
	S	U	S	U
Skill Number 1				
Secure the fire ground, given marking devices, sufficient personnel, and special tools and equipment, so that unauthorized persons can recognize the perimeters of the investigative scene and are kept from restricted areas and all evidence or potential evidence is protected from damage or destruction. (1033-4.2.1)				
a) Located general area of fire origin				
b) Marked items of potential evidence				
c) Verbally described the importance of fire scene security				
d) Placed scene restriction marking devices around the origin area and/or potential evidence items				
e) Verbally described evidence preservation				
f) Verbally described issues relating to spoliation				
g) Prevented unauthorized entry				
h) Performed skill in a safe and proficient manner				

S = Satisfactorily completed/performed

U = Unsatisfactorily performed/failed to meet objective or grading step

All steps of the skill objective are mandatory and must be scored as “Satisfactory” to pass the skill.

Reprinted with permission from NFPA 1033, *Professional Qualifications for Fire Investigator*, Copyright ©2013, National Fire Protection Association, Quincy, MA 02169. This reprinted material is not the complete and official position of the National Fire Protection Association on the referenced subject which is represented only by the standard in its entirety.

TEXAS COMMISSION ON FIRE PROTECTION
Fire Investigator
Performance Standards Evaluation

Examiner/Candidate Comments:

Examiner

Date

Re-Test Examiner

Date

Overall Skill Sheet Score	
Pass <input type="checkbox"/>	Fail <input type="checkbox"/>
Overall Skill Sheet Re-Test Score	
Pass <input type="checkbox"/>	Fail <input type="checkbox"/>

Reprinted with permission from NFPA 1033, *Professional Qualifications for Fire Investigator*, Copyright ©2013, National Fire Protection Association, Quincy, MA 02169. This reprinted material is not the complete and official position of the National Fire Protection Association on the referenced subject which is represented only by the standard in its entirety.

TEXAS COMMISSION ON FIRE PROTECTION
Fire Investigator
Performance Standards Evaluation

Skill Number 2
Conducting an Exterior Survey

Subject: Scene Examination

NFPA 1033, 2014 edition, 4.2.2

Fire Investigator

OBJECTIVE

Conduct an exterior survey, given standard equipment and tools, so that evidence is identified and preserved, fire damage is interpreted, hazards are identified to avoid injuries, accessibility to the property is determined, and all potential means of ingress and egress are discovered. (4.2.2)

INSTRUCTIONS - procedures for achieving the objective

The Investigator candidate, while keeping safety in mind, shall conduct a 360-degree exterior survey of the scene. The Investigator candidate shall identify entry/exit points, items of potential evidence, and post fire indicators.

EXAMINER'S NOTE

The Investigator candidate will not be allowed to review the performance steps at the time of testing.

The fire ground scene may be physically simulated; however, the investigator candidate must perform each step of the required skill in the presence of the field examiner.

PREPARATION & EQUIPMENT

Fire ground (actual or simulated)

Note pad

Camera

Appropriate safety equipment

Reprinted with permission from NFPA 1033, *Professional Qualifications for Fire Investigator*, Copyright ©2013, National Fire Protection Association, Quincy, MA 02169. This reprinted material is not the complete and official position of the National Fire Protection Association on the referenced subject which is represented only by the standard in its entirety.

TEXAS COMMISSION ON FIRE PROTECTION
Fire Investigator
 Performance Standards Evaluation

Candidate: _____ Notes: _____

Training Provider: _____

Test Site: _____

Examiner: _____

Fire Investigator	TEST		RETEST	
	S	U	S	U
Skill Number 2				
Conduct an exterior survey, given standard equipment and tools, so that evidence is identified and preserved, fire damage is interpreted, hazards are identified to avoid injuries, accessibility to the property is determined, and all potential means of ingress and egress are discovered. (1033-4.2.2)				
a) Secured the fire ground				
b) Verbally described the building construction and condition				
c) Conducted an exterior 360-degree survey around the fire ground				
d) Documented observations of the effects of fire suppression				
e) Documented observations of the effects of fire on fire behavior and spread, evidence preservation methods and fire patterns				
f) Marked entry/exit points				
g) Performed skill in a safe and proficient manner				

S = Satisfactorily completed/performed

U = Unsatisfactorily performed/failed to meet objective or grading step

All steps of the skill objective are mandatory and must be scored as "Satisfactory" to pass the skill.

Reprinted with permission from NFPA 1033, *Professional Qualifications for Fire Investigator*, Copyright ©2013, National Fire Protection Association, Quincy, MA 02169. This reprinted material is not the complete and official position of the National Fire Protection Association on the referenced subject which is represented only by the standard in its entirety.

TEXAS COMMISSION ON FIRE PROTECTION
Fire Investigator
Performance Standards Evaluation

Examiner/Candidate Comments:

Examiner

Date

Re-Test Examiner

Date

Overall Skill Sheet Score	
Pass <input type="checkbox"/>	Fail <input type="checkbox"/>
Overall Skill Sheet Re-Test Score	
Pass <input type="checkbox"/>	Fail <input type="checkbox"/>

Reprinted with permission from NFPA 1033, *Professional Qualifications for Fire Investigator*, Copyright ©2013, National Fire Protection Association, Quincy, MA 02169. This reprinted material is not the complete and official position of the National Fire Protection Association on the referenced subject which is represented only by the standard in its entirety.

TEXAS COMMISSION ON FIRE PROTECTION
Fire Investigator
Performance Standards Evaluation

Skill Number 3
Conducting an Interior Survey

Subject: Scene Examination

NFPA 1033, 2014 edition, 4.2.3

Fire Investigator

OBJECTIVE

Conduct an interior survey, given standard equipment and tools, so that areas of potential evidentiary value requiring further examination are identified and preserved, the evidentiary value of contents is determined, and hazards are identified in order to avoid injuries. (4.2.3)

INSTRUCTIONS - procedures for achieving the objective

The Investigator candidate, while keeping safety in mind, shall conduct a 360-degree interior survey of the fire scene. The Investigator candidate shall identify entry/exit points, items of potential evidence, and post fire indicators.

EXAMINER'S NOTE

The Investigator candidate will not be allowed to review the performance steps at the time of testing.

The fire ground scene may be physically simulated; however, the investigator candidate must perform each step of the required skill in the presence of the field examiner.

PREPARATION & EQUIPMENT

Fire ground (actual or simulated)

Note pad

Standard equipment and tools

Appropriate safety equipment

Camera

Reprinted with permission from NFPA 1033, *Professional Qualifications for Fire Investigator*, Copyright ©2015, National Fire Protection Association, Quincy, MA 02169. This reprinted material is not the complete and official position of the National Fire Protection Association on the referenced subject which is represented only by the standard in its entirety.

TEXAS COMMISSION ON FIRE PROTECTION
Fire Investigator
Performance Standards Evaluation

Candidate: _____ Notes: _____

Training Provider: _____

Test Site: _____

Examiner: _____

Fire Investigator	<u>TEST</u>		<u>RETEST</u>	
	S	U	S	U
Skill Number 3				
Conduct an interior survey, given standard equipment and tools, so that areas of potential evidentiary value requiring further examination are identified and preserved, the evidentiary value of contents is determined, and hazards are identified in order to avoid injuries. (1033-4.2.3)				
a) Verbally described the structural condition and interior finish				
b) Conducted a 360-degree interior survey of the fire scene				
c) Documented observations of the effects of fire suppression				
d) Documented observations of the effects of fire on fire behavior and spread, evidence preservation methods and fire patterns				
e) Marked entry/exit points				
f) Evaluated protected areas to determine the presence and/or absence of contents				
g) Performed skill in a safe and proficient manner				

S = Satisfactorily completed/performed

U = Unsatisfactorily performed/failed to meet objective or grading step

All steps of the skill objective are mandatory and must be scored as "Satisfactory" to pass the skill.

Reprinted with permission from NFPA 1033, *Professional Qualifications for Fire Investigator*, Copyright ©2015, National Fire Protection Association, Quincy, MA 02169. This reprinted material is not the complete and official position of the National Fire Protection Association on the referenced subject which is represented only by the standard in its entirety.

TEXAS COMMISSION ON FIRE PROTECTION
Fire Investigator
Performance Standards Evaluation

Examiner/Candidate Comments:

Examiner

Date

Re-Test Examiner

Date

Overall Skill Sheet Score
Pass <input type="checkbox"/> Fail <input type="checkbox"/>
Overall Skill Sheet Re-Test Score
Pass <input type="checkbox"/> Fail <input type="checkbox"/>

Reprinted with permission from NFPA 1033, *Professional Qualifications for Fire Investigator*, Copyright ©2015, National Fire Protection Association, Quincy, MA 02169. This reprinted material is not the complete and official position of the National Fire Protection Association on the referenced subject which is represented only by the standard in its entirety.

TEXAS COMMISSION ON FIRE PROTECTION
Fire Investigator
Performance Standards Evaluation

Skill Number 4
Interpret Fire Patterns in a Vehicle

Subject: Scene Examination

NFPA 1033, 2014 edition, 4.2.4

Fire Investigator

OBJECTIVE

Interpret fire patterns, given standard equipment and tools and some structural or content remains, so that each individual pattern is evaluated with respect to the burning characteristics of the material involved and in context and relationship with all patterns observed and the mechanisms of heat transfer that led to the formation of the pattern. (4.2.4)

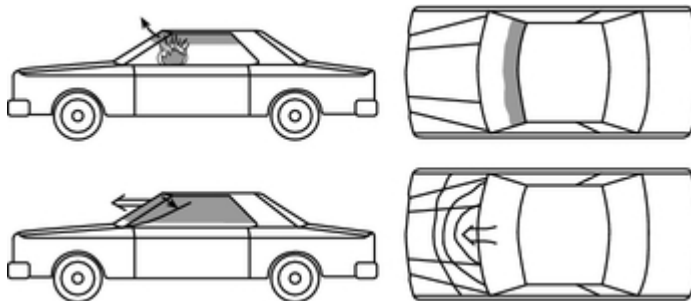

INSTRUCTIONS - procedures for achieving the objective

The Investigator candidate shall observe a vehicle fire scene and interpret fire patterns, given standard equipment and tools and a vehicle, so that each individual pattern is evaluated with respect to the burning characteristics of the material involved.

EXAMINER'S NOTE

The Investigator candidate will not be allowed to review the performance steps at the time of testing.

The fire ground scene may be physically simulated; however, the investigator candidate must perform each step of the required skill in the presence of the field examiner.

Reprinted with permission from NFPA 1033, *Professional Qualifications for Fire Investigator*, Copyright ©2013, National Fire Protection Association, Quincy, MA 02169. This reprinted material is not the complete and official position of the National Fire Protection Association on the referenced subject which is represented only by the standard in its entirety.

TEXAS COMMISSION ON FIRE PROTECTION

Fire Investigator

Performance Standards Evaluation

PREPARATION & EQUIPMENT

Vehicle fire ground (actual or simulated)

Note pad

Standard equipment and tools

Appropriate safety equipment

Reprinted with permission from NFPA 1033, *Professional Qualifications for Fire Investigator*, Copyright ©2013, National Fire Protection Association, Quincy, MA 02169. This reprinted material is not the complete and official position of the National Fire Protection Association on the referenced subject which is represented only by the standard in its entirety.

TEXAS COMMISSION ON FIRE PROTECTION
Fire Investigator
 Performance Standards Evaluation

Candidate: _____ Notes: _____

Training Provider: _____

Test Site: _____

Examiner: _____

Fire Investigator	<u>TEST</u>		<u>RETEST</u>	
	S	U	S	U
Skill Number 4				
Interpret fire patterns, given standard equipment and tools and some structural or content remains, so that each individual pattern is evaluated with respect to the burning characteristics of the material involved and in context and relationship with all patterns observed and the mechanisms of heat transfer that led to the formation of the pattern. (4.2.4)				
a) Interpreted and documented fire patterns and heat transfer mechanisms on different types of materials				
b) Determined an area of origin in or near the vehicle				
c) Examined the engine compartment, the passenger compartment or interior, and the cargo compartment				
d) Interpreted and documented signs of fire development				
e) Performed skill in a safe and proficient manner				

S = Satisfactorily completed/performed

U = Unsatisfactorily performed/failed to meet objective or grading step

All steps of the skill objective are mandatory and must be scored as "Satisfactory" to pass the skill.

Reprinted with permission from NFPA 1033, *Professional Qualifications for Fire Investigator*, Copyright ©2013, National Fire Protection Association, Quincy, MA 02169. This reprinted material is not the complete and official position of the National Fire Protection Association on the referenced subject which is represented only by the standard in its entirety.

TEXAS COMMISSION ON FIRE PROTECTION
Fire Investigator
Performance Standards Evaluation

Examiner/Candidate Comments:

Examiner

Date

Re-Test Examiner

Date

Overall Skill Sheet Score
Pass <input type="checkbox"/> Fail <input type="checkbox"/>
Overall Skill Sheet Re-Test Score
Pass <input type="checkbox"/> Fail <input type="checkbox"/>

Reprinted with permission from NFPA 1033, *Professional Qualifications for Fire Investigator*, Copyright ©2013, National Fire Protection Association, Quincy, MA 02169. This reprinted material is not the complete and official position of the National Fire Protection Association on the referenced subject which is represented only by the standard in its entirety.

TEXAS COMMISSION ON FIRE PROTECTION

Fire Investigator

Performance Standards Evaluation

Skill Number 5

Interpret and Analyze Fire Patterns

Subject: Scene Examination

NFPA 1033, 2014 edition, 4.2.4, 4.2.5

Fire Investigator

OBJECTIVE

Interpret fire patterns, given standard equipment and tools and some structural or content remains, so that each individual pattern is evaluated with respect to the burning characteristics of the material involved and in context and relationship with all patterns observed and the mechanisms of heat transfer that led to the formation of the pattern. (4.2.4)

Interpret and analyze fire patterns, given standard equipment and tools and some structural or content remains, so that fire development is determined, methods and effects of suppression are evaluated, false origin area patterns are recognized, and all areas of origin are correctly identified. (4.2.5)

INSTRUCTIONS - procedures for achieving the objective

The Investigator candidate shall observe a fire scene and interpret and analyze fire patterns, given standard equipment and tools and some structural or content remains, so that fire development is determined, methods and effects of suppression are evaluated, false origin area patterns are recognized, and all areas of origin are correctly identified. Also, each individual pattern is evaluated with respect to the burning characteristics of the material involved.

EXAMINER'S NOTE

The Investigator candidate will not be allowed to review the performance steps at the time of testing.

The fire ground scene may be physically simulated; however, the investigator candidate must perform each step of the required skill in the presence of the field examiner.

PREPARATION & EQUIPMENT

Fire ground (actual or simulated)

Note pad

Camera

Standard equipment and tools

Appropriate safety equipment

Reprinted with permission from NFPA 1033, *Professional Qualifications for Fire Investigator*, Copyright ©2013, National Fire Protection Association, Quincy, MA 02169. This reprinted material is not the complete and official position of the National Fire Protection Association on the referenced subject which is represented only by the standard in its entirety.

TEXAS COMMISSION ON FIRE PROTECTION
Fire Investigator
Performance Standards Evaluation

Candidate: _____ Notes: _____

Training Provider: _____

Test Site: _____

Examiner: _____

Fire Investigator	<u>TEST</u>		<u>RETEST</u>	
	S	U	S	U
Skill Number 5				
Interpret fire patterns, given standard equipment and tools and some structural or content remains, so that each individual pattern is evaluated with respect to the burning characteristics of the material involved and in context and relationship with all patterns observed and the mechanisms of heat transfer that led to the formation of the pattern. (1033-4.2.4)				
Interpret and analyze fire patterns, given standard equipment and tools and some structural or content remains, so that fire development is determined, methods and effects of suppression are evaluated, false origin area patterns are recognized, and all areas of origin are correctly identified. (1033-4.2.5)				
a) Interpreted and analyzed fire patterns and heat transfer mechanisms on different materials with consideration given to heat release rate, form and ignitibility				
b) Verbally distinguished impact of different types of fuel loads				
c) Evaluated and documented fuel trails				
d) Documented the analyzed and synthesized information				
e) Interpreted and documented signs of fire development and fire dynamics				
f) Performed skill in a safe and proficient manner				

S = Satisfactorily completed/performed

U = Unsatisfactorily performed/failed to meet objective or grading step

Reprinted with permission from NFPA 1033, *Professional Qualifications for Fire Investigator*, Copyright ©2013, National Fire Protection Association, Quincy, MA 02169. This reprinted material is not the complete and official position of the National Fire Protection Association on the referenced subject which is represented only by the standard in its entirety.

TEXAS COMMISSION ON FIRE PROTECTION
Fire Investigator
Performance Standards Evaluation

All steps of the skill objective are mandatory and must be scored as “Satisfactory” to pass the skill.

Examiner/Candidate Comments:

Examiner

Date

Overall Skill Sheet Score

Pass Fail

Re-Test Examiner

Date

Overall Skill Sheet Re-Test Score

Pass Fail

Reprinted with permission from NFPA 1033, *Professional Qualifications for Fire Investigator*, Copyright ©2013, National Fire Protection Association, Quincy, MA 02169. This reprinted material is not the complete and official position of the National Fire Protection Association on the referenced subject which is represented only by the standard in its entirety.

TEXAS COMMISSION ON FIRE PROTECTION

Fire Investigator

Performance Standards Evaluation

Skill Number 6

Examining and Removing Fire Debris

Subject: Scene Examination

NFPA 1033, 2014 edition, 4.2.6, 4.2.9

Fire Investigator

OBJECTIVE

Examine and remove fire debris, given standard equipment and tools, so that all debris is checked for fire cause evidence, potential ignition source(s) is identified, and evidence is preserved without investigator-inflicted damage or contamination. (4.2.6)

Discriminate the effects of explosions from other types of damage, given standard equipment and tools, so that an explosion is identified and its evidence is preserved. (4.2.9)

INSTRUCTIONS - procedures for achieving the objective

The Investigator candidate shall, while wearing proper PPE, examine and remove fire debris from a scene. The Investigator candidate shall check all of the debris and the surrounding area for fire cause evidence, including evidence of an explosion. The Investigator candidate shall identify the ignition source(s), determine the cause of the fire, and preserve all evidence properly.

EXAMINER'S NOTE

The Investigator candidate will not be allowed to review the performance steps at the time of testing. Evidence of an explosion must be included so that the candidate's ability to discriminate the effects of an explosion, identify the explosion, and preserve the evidence of the explosion can all be evaluated. Evidence of an explosion might actually be in the debris or surrounding materials at a scene, or it could be photographic evidence presented from a case file.

The fire ground scene may be physically simulated; however, the investigator candidate must perform each step of the required skill in the presence of the field examiner.

PREPARATION & EQUIPMENT

Fire ground with evidence of an explosion (actual or simulated)

Standard equipment and tools

Evidence collection containers

Appropriate safety equipment

Reprinted with permission from NFPA 1033, *Professional Qualifications for Fire Investigator*, Copyright ©2013, National Fire Protection Association, Quincy, MA 02169. This reprinted material is not the complete and official position of the National Fire Protection Association on the referenced subject which is represented only by the standard in its entirety.

TEXAS COMMISSION ON FIRE PROTECTION
Fire Investigator
 Performance Standards Evaluation

Candidate: _____ Notes: _____

Training Provider: _____

Test Site: _____

Examiner: _____

Fire Investigator	<u>TEST</u>		<u>RETEST</u>	
	S	U	S	U
Skill Number 6				
Examine and remove fire debris, given standard equipment and tools, so that all debris is checked for fire cause evidence, potential ignition source(s) is identified, and evidence is preserved without investigator-inflicted damage or contamination. (1033-4.2.6)				
Discriminate the effects of explosions from other types of damage, given standard equipment and tools, so that an explosion is identified and its evidence is preserved. (1033-4.2.9)				
a) Used search techniques that incorporated documentation				
b) Properly examined and removed fire debris				
c) Checked all debris for fire cause evidence				
d) Located and identified the ignition source				
e) Determined the fire cause				
f) Collected and preserved evidence without damage or contamination				
g) Identified and documented explosive effects on glass, walls, foundations, and other building materials				
h) Distinguished and documented between low- and high-order explosion effects				
i) Analyzed damage in order to document the blast zone and origin				
j) Performed skill in a safe and proficient manner				

S = Satisfactorily completed/performed

U = Unsatisfactorily performed/failed to meet objective or grading step

Reprinted with permission from NFPA 1033, *Professional Qualifications for Fire Investigator*, Copyright ©2013, National Fire Protection Association, Quincy, MA 02169. This reprinted material is not the complete and official position of the National Fire Protection Association on the referenced subject which is represented only by the standard in its entirety.

TEXAS COMMISSION ON FIRE PROTECTION
Fire Investigator
Performance Standards Evaluation

All steps of the skill objective are mandatory and must be scored as “Satisfactory” to pass the skill.

Examiner/Candidate Comments:

Examiner

Date

Overall Skill Sheet Score

Pass Fail

Re-Test Examiner

Date

Overall Skill Sheet Re-Test Score

Pass Fail

Reprinted with permission from NFPA 1033, *Professional Qualifications for Fire Investigator*, Copyright ©2013, National Fire Protection Association, Quincy, MA 02169. This reprinted material is not the complete and official position of the National Fire Protection Association on the referenced subject which is represented only by the standard in its entirety.

TEXAS COMMISSION ON FIRE PROTECTION

Fire Investigator

Performance Standards Evaluation

Skill Number 7

Reconstructing the Area of Origin

Subject: Scene Examination

NFPA 1033, 2014 edition, 4.2.7

Fire Investigator

OBJECTIVE

Reconstruct the area of origin, given standard and, if needed, special equipment and tools as well as sufficient personnel, so that all protected areas and fire patterns are identified and correlated to contents or structural remains, items potentially critical to cause determination and photo documentation are returned to their prefire location, and the area(s) or point(s) of origin is discovered. (4.2.7)

INSTRUCTIONS - procedures for achieving the objective

The Investigator candidate shall identify protected areas, locate and replace items moved during fire suppression activities to their pre-fire location, and indicate on a photo log what photos should be taken to document reconstruction.

EXAMINER'S NOTE

The Investigator candidate will not be allowed to review the performance steps at the time of testing.

The fire ground scene may be physically simulated; however, the investigator candidate must perform each step of the required skill in the presence of the field examiner.

PREPARATION & EQUIPMENT

Fire ground (actual or simulated),
Standard equipment and tools
Burned items
Photo log
Appropriate safety equipment
Personnel (if needed)

Reprinted with permission from NFPA 1033, *Professional Qualifications for Fire Investigator*, Copyright ©2013, National Fire Protection Association, Quincy, MA 02169. This reprinted material is not the complete and official position of the National Fire Protection Association on the referenced subject which is represented only by the standard in its entirety.

TEXAS COMMISSION ON FIRE PROTECTION
Fire Investigator
 Performance Standards Evaluation

Candidate: _____ Notes: _____

Training Provider: _____

Test Site: _____

Examiner: _____

Fire Investigator	<u>TEST</u>		<u>RETEST</u>	
	S	U	S	U
Skill Number 7				
Reconstruct the area of origin, given standard and, if needed, special equipment and tools as well as sufficient personnel, so that all protected areas and fire patterns are identified and correlated to contents or structural remains, items potentially critical to cause determination and photo documentation are returned to their prefire location, and the area(s) or point(s) of origin is discovered. (1033-4.2.7)				
a) Examined all materials to determine the effects of fire				
b) Identified and distinguished among different types of fire-damaged contents				
c) Returned materials to their original position using protected areas and fire patterns				
d) Performed skill in a safe and proficient manner				

S = Satisfactorily completed/performed

U = Unsatisfactorily performed/failed to meet objective or grading step

All steps of the skill objective are mandatory and must be scored as "Satisfactory" to pass the skill.

Reprinted with permission from NFPA 1033, *Professional Qualifications for Fire Investigator*, Copyright ©2013, National Fire Protection Association, Quincy, MA 02169. This reprinted material is not the complete and official position of the National Fire Protection Association on the referenced subject which is represented only by the standard in its entirety.

TEXAS COMMISSION ON FIRE PROTECTION
Fire Investigator
Performance Standards Evaluation

Examiner/Candidate Comments:

Examiner

Date

Re-Test Examiner

Date

Overall Skill Sheet Score	
Pass <input type="checkbox"/>	Fail <input type="checkbox"/>
Overall Skill Sheet Re-Test Score	
Pass <input type="checkbox"/>	Fail <input type="checkbox"/>

Reprinted with permission from NFPA 1033, *Professional Qualifications for Fire Investigator*, Copyright ©2013, National Fire Protection Association, Quincy, MA 02169. This reprinted material is not the complete and official position of the National Fire Protection Association on the referenced subject which is represented only by the standard in its entirety.

TEXAS COMMISSION ON FIRE PROTECTION
Fire Investigator
Performance Standards Evaluation

Skill Number 8
Inspecting the Performance of Building Systems

Subject: Scene Examination

NFPA 1033, 2014 edition, 4.2.8

Fire Investigator

OBJECTIVE

Inspect the performance of building systems, including detection, suppression, HVAC, utilities, and building compartmentation, given standard and special equipment and tools, so that a determination can be made as to the need for expert resources, an operating system's impact on fire growth and spread is considered in identifying origin areas, defeated and/or failed systems are identified, and the system's potential as a fire cause is recognized. (4.2.8)

INSTRUCTIONS - procedures for achieving the objective

The Investigator candidate shall perform a post-fire inspection of a scene and indicate on a floor plan the location and condition of each of the following: detection systems, HVAC, utilities, and suppression systems. The Investigator candidate shall identify which expert resources, if any, would be needed to confirm that any of the systems were found defective or defeated.

EXAMINER'S NOTE

The Investigator candidate will not be allowed to review the performance steps at the time of testing.

The fire ground scene may be physically simulated; however, the investigator candidate must perform each step of the required skill in the presence of the field examiner.

PREPARATION AND EQUIPMENT

Fire ground (actual and simulated)
Floor plan
Building systems
Appropriate safety equipment
Standard equipment and tools

Reprinted with permission from NFPA 1033, *Professional Qualifications for Fire Investigator*, Copyright ©2013, National Fire Protection Association, Quincy, MA 02169. This reprinted material is not the complete and official position of the National Fire Protection Association on the referenced subject which is represented only by the standard in its entirety.

TEXAS COMMISSION ON FIRE PROTECTION
Fire Investigator
 Performance Standards Evaluation

Candidate: _____ Notes: _____

Training Provider: _____

Test Site: _____

Examiner: _____

Fire Investigator	TEST		RETEST	
	S	U	S	U
Skill Number 8				
Inspect the performance of building systems, including detection, suppression, HVAC, utilities, and building compartmentation, given standard and special equipment and tools, so that a determination can be made as to the need for expert resources, an operating system's impact on fire growth and spread is considered in identifying origin areas, defeated and/or failed systems are identified, and the system's potential as a fire cause is recognized. (1033-4.2.8)				
a) Identified and inspected exterior utilities				
b) Located and inspected detection systems				
c) Located and inspected HVAC systems				
d) Located and inspected suppression systems				
e) Reported which, if any, expert resources would be needed				
f) Reported which, if any and how systems inspected were defective or defeated				
g) Documented the building systems effect on the fire and fire suppression efforts on building systems				
h) Performed skill in a safe and proficient manner				

S = Satisfactorily completed/performed

U = Unsatisfactorily performed/failed to meet objective or grading step

All steps of the skill objective are mandatory and must be scored as "Satisfactory" to pass the skill.

Reprinted with permission from NFPA 1033, *Professional Qualifications for Fire Investigator*, Copyright ©2013, National Fire Protection Association, Quincy, MA 02169. This reprinted material is not the complete and official position of the National Fire Protection Association on the referenced subject which is represented only by the standard in its entirety.

TEXAS COMMISSION ON FIRE PROTECTION
Fire Investigator
Performance Standards Evaluation

Examiner/Candidate Comments:

Examiner

Date

Re-Test Examiner

Date

Overall Skill Sheet Score	
Pass <input type="checkbox"/>	Fail <input type="checkbox"/>
Overall Skill Sheet Re-Test Score	
Pass <input type="checkbox"/>	Fail <input type="checkbox"/>

Reprinted with permission from NFPA 1033, *Professional Qualifications for Fire Investigator*, Copyright ©2013, National Fire Protection Association, Quincy, MA 02169. This reprinted material is not the complete and official position of the National Fire Protection Association on the referenced subject which is represented only by the standard in its entirety.

TEXAS COMMISSION ON FIRE PROTECTION
Fire Investigator
Performance Standards Evaluation

Skill Number 9
Diagramming the Scene

Subject: Documenting the Scene

NFPA 1033, 2014 edition, 4.3.1

Fire Investigator

OBJECTIVE

Diagram the scene, given standard tools and equipment, so that the scene is accurately represented and evidence, pertinent contents, significant patterns, and area(s) or point(s) of origin are identified. (4.3.1)

INSTRUCTIONS - procedures for achieving the objective

The Investigator candidate shall diagram (rough sketch) the fire scene. Diagram shall include at least one item of evidence, one item of pertinent contents, one significant fire pattern, and one area or point of origin.

EXAMINER'S NOTE

The Investigator candidate will not be allowed to review the performance steps at the time of testing.

The fire ground scene may be physically simulated; however, the investigator candidate must perform each step of the required skill in the presence of the field examiner.

PREPARATION & EQUIPMENT

Safe and secure fire ground (actual or simulated)

Note pad

Measuring devices

An assistant if requested

Appropriate safety equipment

Standard equipment and tools

Reprinted with permission from NFPA 1033, *Professional Qualifications for Fire Investigator*, Copyright ©2013, National Fire Protection Association, Quincy, MA 02169. This reprinted material is not the complete and official position of the National Fire Protection Association on the referenced subject which is represented only by the standard in its entirety.

TEXAS COMMISSION ON FIRE PROTECTION
Fire Investigator
Performance Standards Evaluation

Candidate: _____ Notes: _____

Training Provider: _____

Test Site: _____

Examiner: _____

Fire Investigator	<u>TEST</u>		<u>RETEST</u>	
	S	U	S	U
Skill Number 9				
Diagram the scene, given standard tools and equipment, so that the scene is accurately represented and evidence, pertinent contents, significant patterns, and area(s) or point(s) of origin are identified. (1033-4.3.1)				
Diagrammed the fire scene to include each of the following:				
1) Relative locations, dimensions, rooms, stairs, doors and windows				
2) At least one item of evidence with location dimensions indicated				
3) At least one item of pertinent contents with location and dimensions indicated				
4) At least one fire pattern with location identified				
5) Performed skill in a safe and proficient manner				

S = Satisfactorily completed/performed

U = Unsatisfactorily performed/failed to meet objective or grading step

All steps of the skill objective are mandatory and must be scored as “Satisfactory” to pass the skill.

Reprinted with permission from NFPA 1033, *Professional Qualifications for Fire Investigator*, Copyright ©2013, National Fire Protection Association, Quincy, MA 02169. This reprinted material is not the complete and official position of the National Fire Protection Association on the referenced subject which is represented only by the standard in its entirety.

TEXAS COMMISSION ON FIRE PROTECTION
Fire Investigator
Performance Standards Evaluation

Examiner/Candidate Comments:

Examiner

Date

Re-Test Examiner

Date

Overall Skill Sheet Score	
Pass <input type="checkbox"/>	Fail <input type="checkbox"/>
Overall Skill Sheet Re-Test Score	
Pass <input type="checkbox"/>	Fail <input type="checkbox"/>

Reprinted with permission from NFPA 1033, *Professional Qualifications for Fire Investigator*, Copyright ©2013, National Fire Protection Association, Quincy, MA 02169. This reprinted material is not the complete and official position of the National Fire Protection Association on the referenced subject which is represented only by the standard in its entirety.

TEXAS COMMISSION ON FIRE PROTECTION
Fire Investigator
Performance Standards Evaluation

Skill Number 10
Photographically Documenting the Scene

Subject: Documenting the Scene

NFPA 1033, 2014 edition, 4.3.2

Fire Investigator

OBJECTIVE

Photographically document the scene, given standard tools and equipment, so that the scene is accurately depicted and the photographs support scene findings. (4.3.2)

INSTRUCTIONS - procedures for achieving the objective

The Investigator candidate shall photograph an interior scene and provide a photo log and rough sketch of the photo(s) taken.

EXAMINER'S NOTE

The Investigator candidate will not be allowed to review the performance steps at the time of testing.

The fire ground scene may be physically simulated; however, the investigator candidate must perform each step of the required skill in the presence of the field examiner.

PREPARATION & EQUIPMENT

Fire ground (actual or simulated)
High-resolution camera, flash, and accessories
Note pad
Measuring devices
Photo log
Appropriate safety equipment
Standard equipment and tools

Reprinted with permission from NFPA 1033, *Professional Qualifications for Fire Investigator*, Copyright ©2013, National Fire Protection Association, Quincy, MA 02169. This reprinted material is not the complete and official position of the National Fire Protection Association on the referenced subject which is represented only by the standard in its entirety.

TEXAS COMMISSION ON FIRE PROTECTION
Fire Investigator
 Performance Standards Evaluation

Candidate: _____ Notes: _____

Training Provider: _____

Test Site: _____

Examiner: _____

Skill Number 10	<u>TEST</u>		<u>RETEST</u>	
	S	U	S	U
Photographically document the scene, given standard tools and equipment, so that the scene is accurately depicted and the photographs support scene findings. (1033-4.3.2)				
a) Photographed exterior survey				
b) Photographed interior survey				
c) Documented photos taken on a photo rough sketch and photo log				
d) Performed skill in a safe and proficient manner				

S = Satisfactorily completed/performed

U = Unsatisfactorily performed/failed to meet objective or grading step

All steps of the skill objective are mandatory and must be scored as "Satisfactory" to pass the skill.

Examiner/Candidate Comments:

 Examiner

 Date

 Re-Test Examiner

 Date

Overall Skill Sheet Score	
Pass <input type="checkbox"/>	Fail <input type="checkbox"/>
Overall Skill Sheet Re-Test Score	
Pass <input type="checkbox"/>	Fail <input type="checkbox"/>

Reprinted with permission from NFPA 1033, *Professional Qualifications for Fire Investigator*, Copyright ©2013, National Fire Protection Association, Quincy, MA 02169. This reprinted material is not the complete and official position of the National Fire Protection Association on the referenced subject which is represented only by the standard in its entirety.

TEXAS COMMISSION ON FIRE PROTECTION

Fire Investigator

Performance Standards Evaluation

Skill Number 11

Constructing Investigative Notes

Subject: Documenting the Scene

NFPA 1033, 2014 edition, 4.3.3

Fire Investigator

OBJECTIVE

Construct investigative notes, given a fire scene, available documents (e.g. prefire plans and inspection reports), and interview information, so that the notes are accurate, provide further documentation of the scene, and represent complete documentation of the scene findings. (4.3.3)

INSTRUCTIONS - procedures for achieving the objective

The investigator candidate shall take field notes from the scene to be used to compile a final report. The field notes shall include a documented exterior survey, interior survey, area of origin and fire patterns. You will correlate photos and interview information to the fire scene.

EXAMINER'S NOTE

The Investigator candidate will not be allowed to review the performance steps at the time of testing.

The fire ground scene may be physically simulated; however, the investigator candidate must perform each step of the required skill in the presence of the field examiner.

PREPARATION & EQUIPMENT

Fire scene, actual or simulated

An investigation file including:

- Interview information
- Photos
- Suppression report
- Any available pre-fire information

Reprinted with permission from NFPA 1033, *Professional Qualifications for Fire Investigator*, Copyright ©2013, National Fire Protection Association, Quincy, MA 02169. This reprinted material is not the complete and official position of the National Fire Protection Association on the referenced subject which is represented only by the standard in its entirety.

TEXAS COMMISSION ON FIRE PROTECTION
Fire Investigator
Performance Standards Evaluation

Candidate: _____ Notes: _____

Training Provider: _____

Test Site: _____

Examiner: _____

Fire Investigator	<u>TEST</u>		<u>RETEST</u>	
	S	U	S	U
Skill Number 11				
Construct investigative notes, given a fire scene, available documents (e.g. prefire plans and inspection reports), and interview information, so that the notes are accurate, provide further documentation of the scene, and represent complete documentation of the scene findings. (1033-4.3.3)				
a) Reduced scene observations to reliable and accurate notes				
b) Documented exterior survey, interior survey, area of origin and fire patterns				
c) Correlated photos and interview information to fire scene observations				
d) Performed skill in a safe and proficient manner				

S = Satisfactorily completed/performed

U = Unsatisfactorily performed/failed to meet objective or grading step

All steps of the skill objective are mandatory and must be scored as “Satisfactory” to pass the skill.

Reprinted with permission from NFPA 1033, *Professional Qualifications for Fire Investigator*, Copyright ©2013, National Fire Protection Association, Quincy, MA 02169. This reprinted material is not the complete and official position of the National Fire Protection Association on the referenced subject which is represented only by the standard in its entirety.

TEXAS COMMISSION ON FIRE PROTECTION
Fire Investigator
Performance Standards Evaluation

Examiner/Candidate Comments:

Examiner

Date

Re-Test Examiner

Date

Overall Skill Sheet Score	
Pass <input type="checkbox"/>	Fail <input type="checkbox"/>
Overall Skill Sheet Re-Test Score	
Pass <input type="checkbox"/>	Fail <input type="checkbox"/>

Reprinted with permission from NFPA 1033, *Professional Qualifications for Fire Investigator*, Copyright ©2013, National Fire Protection Association, Quincy, MA 02169. This reprinted material is not the complete and official position of the National Fire Protection Association on the referenced subject which is represented only by the standard in its entirety.

TEXAS COMMISSION ON FIRE PROTECTION

Fire Investigator

Performance Standards Evaluation

Skill Number 12

Utilizing Proper Procedures for Managing Victims and Fatalities

Subject: Evidence Collection/Preservation

NFPA 1033, 2014 edition, 4.4.1, 4.4.2, 4.4.3

Fire Investigator

OBJECTIVE

Utilize proper procedures for managing victims and fatalities, given a protocol and appropriate personnel, so that all evidence is discovered and preserved and the protocol procedures are followed. (4.4.1)

Locate, document, collect, label, package and store evidence, given standard or special tools and equipment and evidence collection materials, so that it is properly identified, preserved, collected, packaged and stored for use in testing, legal, or other proceedings and examinations, ensuring cross-contamination and investigator-inflicted damage to evidentiary items is avoided and the chain of custody is established. (4.4.2)

Select evidence for analysis given all information from the investigation, so that items for analysis support specific investigation needs. (4.4.3)

INSTRUCTIONS - procedures for achieving the objective

The Investigator candidate shall follow procedures to manage victims **AND** fatalities and to discover and preserve **ALL** evidence. The Investigator candidate shall then collect and package two different types of identified evidence, fill out a standard crime lab analysis request form indicating specific test(s) requested, while maintaining chain of custody and avoiding contamination.

EXAMINER'S NOTE

The Investigator candidate will not be allowed to review the performance steps at the time of testing.

The fire ground scene may be physically simulated; however, the investigator candidate must perform each step of the required skill in the presence of the field examiner.

Reprinted with permission from NFPA 1033, *Professional Qualifications for Fire Investigator*, Copyright ©2013, National Fire Protection Association, Quincy, MA 02169. This reprinted material is not the complete and official position of the National Fire Protection Association on the referenced subject which is represented only by the standard in its entirety.

TEXAS COMMISSION ON FIRE PROTECTION

Fire Investigator

Performance Standards Evaluation

PREPARATION & EQUIPMENT

Fire ground, actual or simulated
Several types of evidence
A standard crime lab analysis request form
Needed evidence collection supplies
Note pad
Camera
Simulated victim or fatality
Appropriate safety equipment
Standard equipment and tools

Reprinted with permission from NFPA 1033, *Professional Qualifications for Fire Investigator*, Copyright ©2013, National Fire Protection Association, Quincy, MA 02169. This reprinted material is not the complete and official position of the National Fire Protection Association on the referenced subject which is represented only by the standard in its entirety.

TEXAS COMMISSION ON FIRE PROTECTION
Fire Investigator
Performance Standards Evaluation

Candidate: _____ Notes: _____

Training Provider: _____

Test Site: _____

Examiner: _____

	<u>TEST</u>		<u>RETEST</u>	
	S	U	S	U
Skill Number 12				
Utilize proper procedures for managing victims and fatalities, given a protocol and appropriate personnel, so that all evidence is discovered and preserved and the protocol procedures are followed. (1033-4.4.1)				
Locate, document, collect, label, package and store evidence, given standard or special tools and equipment and evidence collection materials, so that it is properly identified, preserved, collected, packaged and stored for use in testing, legal, or other proceedings and examinations, ensuring cross-contamination and investigator-inflicted damage to evidentiary items is avoided and the chain of custody is established. (1033-4.4.2)				
Select evidence for analysis given all information from the investigation, so that items for analysis support specific investigation needs. (1033-4.4.3)				
a) Utilized proper procedures to manage victims and fatalities				
b) Properly discovered and preserved all evidence				
c) Identified two different types of evidence				
d) Selected, documented and collected one of each of the two types of evidence				
e) Packaged, labeled and stored selected/collected items				
f) Ensured cross-contamination and investigator-inflicted damage to evidentiary items is avoided				
g) Properly completed the crime lab analysis request				

Reprinted with permission from NFPA 1033, *Professional Qualifications for Fire Investigator*, Copyright ©2013, National Fire Protection Association, Quincy, MA 02169. This reprinted material is not the complete and official position of the National Fire Protection Association on the referenced subject which is represented only by the standard in its entirety.

TEXAS COMMISSION ON FIRE PROTECTION
Fire Investigator
 Performance Standards Evaluation

form indicating the specific analysis requested				
h) Documented the process in field notes and photography				
i) Performed skill in a safe and proficient manner				

S = Satisfactorily completed/performed

U = Unsatisfactorily performed/failed to meet objective or grading step

All steps of the skill objective are mandatory and must be scored as "Satisfactory" to pass the skill.

Examiner/Candidate Comments:

 Examiner

 Date

 Re-Test Examiner

 Date

Overall Skill Sheet Score	
Pass <input type="checkbox"/>	Fail <input type="checkbox"/>
Overall Skill Sheet Re-Test Score	
Pass <input type="checkbox"/>	Fail <input type="checkbox"/>

Reprinted with permission from NFPA 1033, *Professional Qualifications for Fire Investigator*, Copyright ©2013, National Fire Protection Association, Quincy, MA 02169. This reprinted material is not the complete and official position of the National Fire Protection Association on the referenced subject which is represented only by the standard in its entirety.

TEXAS COMMISSION ON FIRE PROTECTION

Fire Investigator

Performance Standards Evaluation

Skill Number 13

Maintaining a Chain of Custody

Subject: Evidence Collection/Preservation

NFPA 1033, 2014 edition, 4.4.4

Fire Investigator

OBJECTIVE

Maintain a chain of custody, given standard investigative tools; marking tools, and evidence tags or logs, so that written documentation exists for each piece of evidence and evidence is secured. (4.4.4)

INSTRUCTIONS - procedures for achieving the objective

The Investigator candidate shall mark, package, transfer custody and log two items of evidence.

EXAMINER'S NOTE

The Investigator candidate will not be allowed to review the performance steps at the time of testing.

PREPARATION & EQUIPMENT

Forms

Tags

Two items of evidence

Appropriate safety equipment

Standard equipment and tools

TEXAS COMMISSION ON FIRE PROTECTION
Fire Investigator
 Performance Standards Evaluation

Candidate: _____ Notes: _____

Training Provider: _____

Test Site: _____

Examiner: _____

Fire Investigator	<u>TEST</u>		<u>RETEST</u>	
	S	U	S	U
Skill Number 13				
Maintain a chain of custody, given standard investigative tools, marking tools, and evidence tags or logs, so that written documentation exists for each piece of evidence and evidence is secured. (1033-4.4.4)				
a) Marked and/or tagged and packaged two pieces of evidence				
b) Maintained chain of custody by correctly utilizing logs and/or forms during the transfer of evidence				
c) Performed skill in a safe and proficient manner				

S = Satisfactorily completed/performed

U = Unsatisfactorily performed/failed to meet objective or grading step

All steps of the skill objective are mandatory and must be scored as “Satisfactory” to pass the skill.

Reprinted with permission from NFPA 1033, *Professional Qualifications for Fire Investigator*, Copyright ©2013, National Fire Protection Association, Quincy, MA 02169. This reprinted material is not the complete and official position of the National Fire Protection Association on the referenced subject which is represented only by the standard in its entirety.

TEXAS COMMISSION ON FIRE PROTECTION
Fire Investigator
Performance Standards Evaluation

Examiner/Candidate Comments:

Examiner

Date

Re-Test Examiner

Date

Overall Skill Sheet Score	
Pass <input type="checkbox"/>	Fail <input type="checkbox"/>
Overall Skill Sheet Re-Test Score	
Pass <input type="checkbox"/>	Fail <input type="checkbox"/>

Reprinted with permission from NFPA 1033, *Professional Qualifications for Fire Investigator*, Copyright ©2013, National Fire Protection Association, Quincy, MA 02169. This reprinted material is not the complete and official position of the National Fire Protection Association on the referenced subject which is represented only by the standard in its entirety.

TEXAS COMMISSION ON FIRE PROTECTION
Fire Investigator
Performance Standards Evaluation

Skill Number 14
Disposing of Evidence

Subject: Evidence Collection/Preservation

NFPA 1033, 2014 edition, 4.4.5

Fire Investigator

OBJECTIVE

Dispose of evidence, given jurisdictional or agency regulations and file information, so that the disposal is timely, safely conducted, and in compliance with jurisdictional or agency requirements. (4.4.5)

INSTRUCTIONS - procedures for achieving the objective

The Investigator candidate shall dispose of evidence in a timely and safe manner and document the disposal of evidence.

EXAMINER'S NOTE

The Investigator candidate will not be allowed to review the performance steps at the time of testing.

PREPARATION & EQUIPMENT

Incident information
Model evidence policy
Evidence
Evidence disposal forms

Reprinted with permission from NFPA 1033, *Professional Qualifications for Fire Investigator*, Copyright ©2013, National Fire Protection Association, Quincy, MA 02169. This reprinted material is not the complete and official position of the National Fire Protection Association on the referenced subject which is represented only by the standard in its entirety.

TEXAS COMMISSION ON FIRE PROTECTION
Fire Investigator
 Performance Standards Evaluation

Candidate: _____ Notes: _____

Training Provider: _____

Test Site: _____

Examiner: _____

Fire Investigator	<u>TEST</u>		<u>RETEST</u>	
	S	U	S	U
Skill Number 14				
Dispose of evidence, given jurisdictional or agency regulations and file information, so that the disposal is timely, safely conducted, and in compliance with jurisdictional or agency requirements. (1033-4.4.5)				
a) Identified evidence subject to disposal				
b) Disposed of evidence according to the model evidence policy				
c) Documented disposal of the evidence using the provided forms				
d) Performed skill in a safe and proficient manner				

S = Satisfactorily completed/performed

U = Unsatisfactorily performed/failed to meet objective or grading step

All steps of the skill objective are mandatory and must be scored as "Satisfactory" to pass the skill.

Reprinted with permission from NFPA 1033, *Professional Qualifications for Fire Investigator*, Copyright ©2013, National Fire Protection Association, Quincy, MA 02169. This reprinted material is not the complete and official position of the National Fire Protection Association on the referenced subject which is represented only by the standard in its entirety.

TEXAS COMMISSION ON FIRE PROTECTION
Fire Investigator
Performance Standards Evaluation

Examiner/Candidate Comments:

Examiner

Date

Re-Test Examiner

Date

Overall Skill Sheet Score	
Pass <input type="checkbox"/>	Fail <input type="checkbox"/>
Overall Skill Sheet Re-Test Score	
Pass <input type="checkbox"/>	Fail <input type="checkbox"/>

Reprinted with permission from NFPA 1033, *Professional Qualifications for Fire Investigator*, Copyright ©2013, National Fire Protection Association, Quincy, MA 02169. This reprinted material is not the complete and official position of the National Fire Protection Association on the referenced subject which is represented only by the standard in its entirety.

TEXAS COMMISSION ON FIRE PROTECTION
Fire Investigator
Performance Standards

Skill Number 15
Developing an Interview Plan

Subject: Interview

NFPA 1033, 2014 edition, 4.5.1

Fire Investigator

OBJECTIVE

Develop an interview plan, given no special tools or equipment, so that the plan reflects a strategy to further determine the fire cause and affix responsibility and includes a relevant questioning strategy for each individual to be interviewed that promotes the efficient use of the investigator's time. (4.5.1)

INSTRUCTIONS - procedures for achieving the objective

The Investigator candidate shall develop an interview plan that assists in fire cause and suspect determination.

EXAMINER'S NOTE

The Investigator candidate will not be allowed to review the performance steps at the time of testing.

PREPARATION & EQUIPMENT

Incident information
Witness statement
Notepad

Reprinted with permission from NFPA 1033, *Professional Qualifications for Fire Investigator*, Copyright ©2013, National Fire Protection Association, Quincy, MA 02169. This reprinted material is not the complete and official position of the National Fire Protection Association on the referenced subject which is represented only by the standard in its entirety.

TEXAS COMMISSION ON FIRE PROTECTION
Fire Investigator
Performance Standards

Candidate: _____ Notes: _____

Training Provider: _____

Test Site: _____

Examiner: _____

Fire Investigator	<u>TEST</u>		<u>RETEST</u>	
	PASS	FAIL	PASS	FAIL
Skill Number 15				
Develop an interview plan, given no special tools or equipment, so that the plan reflects a strategy to further determine the fire cause and affix responsibility and includes a relevant questioning strategy for each individual to be interviewed that promotes the efficient use of the investigator's time. (1033-4.5.1)				
The candidate:	S	U	S	U
a) Reviewed provided information and requested additional information if needed				
b) Developed an interview plan strategy for a person of interest				
c) Documented the interview strategy by listing relevant questions				
d) Verbally identified the pros and cons of doing interviews versus document gathering				
e) Performed skill in a safe and proficient manner				

S = Satisfactorily completed/performed

U = Unsatisfactorily performed/failed to meet objective or grading step

All steps of the skill objective are mandatory and must be scored as "Satisfactory" to pass the skill.

Reprinted with permission from NFPA 1033, *Professional Qualifications for Fire Investigator*, Copyright ©2013, National Fire Protection Association, Quincy, MA 02169. This reprinted material is not the complete and official position of the National Fire Protection Association on the referenced subject which is represented only by the standard in its entirety.

TEXAS COMMISSION ON FIRE PROTECTION
Fire Investigator
Performance Standards

Examiner/Candidate Comments:

_____	_____	Overall Skill Sheet Score
Examiner	Date	Pass <input type="checkbox"/> Fail <input type="checkbox"/>
_____	_____	Overall Skill Sheet Re-Test Score
Re-Test Examiner	Date	Pass <input type="checkbox"/> Fail <input type="checkbox"/>

Reprinted with permission from NFPA 1033, *Professional Qualifications for Fire Investigator*, Copyright ©2013, National Fire Protection Association, Quincy, MA 02169. This reprinted material is not the complete and official position of the National Fire Protection Association on the referenced subject which is represented only by the standard in its entirety.

TEXAS COMMISSION ON FIRE PROTECTION
Fire Investigator
Performance Standards Evaluation

Skill Number 16
Conducting Interviews

Subject: Interview

NFPA 1033, 2014 edition, 4.5.2

Fire Investigator

OBJECTIVE

Conduct interviews, given incident information, so that pertinent information is obtained, follow-up questions are asked, responses to all questions are elicited, and the response to each question is documented accurately. (4.5.2)

INSTRUCTIONS - procedures for achieving the objective

The Investigator candidate shall conduct a witness interview. During the interview, the witness shall become a suspect. The Investigator candidate shall change questioning techniques and conduct an interrogation.

EXAMINER'S NOTE

The Investigator candidate will not be allowed to review the performance steps at the time of testing.

PREPARATION & EQUIPMENT

Interview room setting
Incident information
Witness statement
Forms
Note pad

Reprinted with permission from NFPA 1033, *Professional Qualifications for Fire Investigator*, Copyright ©2013, National Fire Protection Association, Quincy, MA 02169. This reprinted material is not the complete and official position of the National Fire Protection Association on the referenced subject which is represented only by the standard in its entirety.

TEXAS COMMISSION ON FIRE PROTECTION
Fire Investigator
 Performance Standards Evaluation

Candidate: _____ Notes: _____

Training Provider: _____

Test Site: _____

Examiner: _____

Fire Investigator	<u>TEST</u>		<u>RETEST</u>	
	S	U	S	U
Skill Number 16				
Conduct interviews, given incident information, so that pertinent information is obtained, follow-up questions are asked, responses to all questions are elicited, and the response to each question is documented accurately. (1033-4.5.2)				
a) Obtained incident briefing and took notes				
b) Identified the witness				
c) Conducted and documented the interview				
d) Recognized when witness became a suspect				
e) Applied legal requirements applicable				
f) Conducted and documented the interrogation				
g) Interpreted verbal and nonverbal communications				
h) Exhibited strong listening skills				
i) Performed skill in a safe and proficient manner				

S = Satisfactorily completed/performed

U = Unsatisfactorily performed/failed to meet objective or grading step

All steps of the skill objective are mandatory and must be scored as "Satisfactory" to pass the skill.

Reprinted with permission from NFPA 1033, *Professional Qualifications for Fire Investigator*, Copyright ©2013, National Fire Protection Association, Quincy, MA 02169. This reprinted material is not the complete and official position of the National Fire Protection Association on the referenced subject which is represented only by the standard in its entirety.

TEXAS COMMISSION ON FIRE PROTECTION
Fire Investigator
Performance Standards Evaluation

Examiner/Candidate Comments:

Examiner

Date

Re-Test Examiner

Date

Overall Skill Sheet Score
Pass <input type="checkbox"/> Fail <input type="checkbox"/>
Overall Skill Sheet Re-Test Score
Pass <input type="checkbox"/> Fail <input type="checkbox"/>

Reprinted with permission from NFPA 1033, *Professional Qualifications for Fire Investigator*, Copyright ©2013, National Fire Protection Association, Quincy, MA 02169. This reprinted material is not the complete and official position of the National Fire Protection Association on the referenced subject which is represented only by the standard in its entirety.

TEXAS COMMISSION ON FIRE PROTECTION

Fire Investigator

Performance Standards Evaluation

Skill Number 17

Evaluating Interview Information

Subject: Interview

NFPA 1033, 2014 edition, 4.5.3

Fire Investigator

OBJECTIVE

Evaluate interview information, given interview transcripts or notes and incident data, so that all interview data is individually analyzed and correlated with all other interviews, corroborative and conflictive information is documented, and new leads are developed. (4.5.3)

INSTRUCTIONS - procedures for achieving the objective

The Investigator candidate shall evaluate, analyze, and correlate interview information to determine if the information is corroborative or conflictive in nature, and develop new investigative leads.

EXAMINER'S NOTE

The Investigator candidate will not be allowed to review the performance steps at the time of testing.

PREPARATION & EQUIPMENT

Incident information
Interview transcripts
Note pad

Reprinted with permission from NFPA 1033, *Professional Qualifications for Fire Investigator*, Copyright ©2013, National Fire Protection Association, Quincy, MA 02169. This reprinted material is not the complete and official position of the National Fire Protection Association on the referenced subject which is represented only by the standard in its entirety.

TEXAS COMMISSION ON FIRE PROTECTION
Fire Investigator
 Performance Standards Evaluation

Candidate: _____ Notes: _____

Training Provider: _____

Test Site: _____

Examiner: _____

Fire Investigator	<u>TEST</u>		<u>RETEST</u>	
	S	U	S	U
Skill Number 17				
Evaluate interview information, given interview transcripts or notes and incident data, so that all interview data is individually analyzed and correlated with all other interviews, corroborative and conflictive information is documented, and new leads are developed. (1033-4.5.3)				
a) Reviewed provided information				
b) Correlated information into corroborative or conflicting groups				
c) Documented new investigative leads				
d) Performed skill in a safe and proficient manner				

S = Satisfactorily completed/performed

U = Unsatisfactorily performed/failed to meet objective or grading step

All steps of the skill objective are mandatory and must be scored as “Satisfactory” to pass the skill.

Examiner/Candidate Comments:

Reprinted with permission from NFPA 1033, *Professional Qualifications for Fire Investigator*, Copyright ©2013, National Fire Protection Association, Quincy, MA 02169. This reprinted material is not the complete and official position of the National Fire Protection Association on the referenced subject which is represented only by the standard in its entirety.

TEXAS COMMISSION ON FIRE PROTECTION
Fire Investigator
Performance Standards Evaluation

Examiner

Date

Overall Skill Sheet Score

Pass Fail

Re-Test Examiner

Date

Overall Skill Sheet Re-Test Score

Pass Fail

Reprinted with permission from NFPA 1033, *Professional Qualifications for Fire Investigator*, Copyright ©2013, National Fire Protection Association, Quincy, MA 02169. This reprinted material is not the complete and official position of the National Fire Protection Association on the referenced subject which is represented only by the standard in its entirety.

TEXAS COMMISSION ON FIRE PROTECTION

Fire Investigator

Performance Standards Evaluation

Skill Number 18

Gathering Reports and Records

Subject: Post-Incident Investigation

NFPA 1033, 2014 edition, 4.6.1

Fire Investigator

OBJECTIVE

Gather reports and records, given no special tools, equipment, or materials, so that all gathered documents are applicable to the investigation, complete, and authentic; the chain of custody is maintained; and the material is admissible in a legal proceeding. (4.6.1)

INSTRUCTIONS - procedures for achieving the objective

The Investigator candidate shall gather reports/records given no special tools, equipment, or materials, so that all gathered documents are appropriate to the investigation, complete and authentic, and the chain of custody is maintained.

EXAMINER'S NOTE

The Investigator candidate will not be allowed to review the performance steps at the time of testing.

PREPARATION & EQUIPMENT

Several different sources of reports and records

TEXAS COMMISSION ON FIRE PROTECTION
Fire Investigator
Performance Standards Evaluation

Candidate: _____ Notes: _____

Training Provider: _____

Test Site: _____

Examiner: _____

Fire Investigator	<u>TEST</u>		<u>RETEST</u>	
	S	U	S	U
Skill Number 18				
Gather reports and records, given no special tools, equipment, or materials, so that all gathered documents are applicable to the investigation, complete, and authentic; the chain of custody is maintained; and the material is admissible in a legal proceeding. (1033-4.6.1)				
a) Reviewed provided materials				
b) Identified additional needed materials				
c) Verbally explained how you would obtain the requested materials				
d) Verbally explained how you would maintain chain of custody of requested documents				
e) Performed skill in a safe and proficient manner				

S = Satisfactorily completed/performed

U = Unsatisfactorily performed/failed to meet objective or grading step

All steps of the skill objective are mandatory and must be scored as “Satisfactory” to pass the skill.

Reprinted with permission from NFPA 1033, *Professional Qualifications for Fire Investigator*, Copyright ©2013, National Fire Protection Association, Quincy, MA 02169. This reprinted material is not the complete and official position of the National Fire Protection Association on the referenced subject which is represented only by the standard in its entirety.

TEXAS COMMISSION ON FIRE PROTECTION
Fire Investigator
Performance Standards Evaluation

Examiner/Candidate Comments:

Examiner

Date

Re-Test Examiner

Date

Overall Skill Sheet Score
Pass <input type="checkbox"/> Fail <input type="checkbox"/>
Overall Skill Sheet Re-Test Score
Pass <input type="checkbox"/> Fail <input type="checkbox"/>

Reprinted with permission from NFPA 1033, *Professional Qualifications for Fire Investigator*, Copyright ©2013, National Fire Protection Association, Quincy, MA 02169. This reprinted material is not the complete and official position of the National Fire Protection Association on the referenced subject which is represented only by the standard in its entirety.

TEXAS COMMISSION ON FIRE PROTECTION

Fire Investigator

Performance Standards Evaluation

Skill Number 19

Evaluating the Investigative File

Subject: Post-Incident Investigation

NFPA 1033, 2014 edition, 4.6.2

Fire Investigator

OBJECTIVE

Evaluate the investigative file, given all available file information, so that areas for further investigation are identified, the relationship between gathered documents and information is interpreted, and corroborative evidence and information discrepancies are discovered. (4.6.2)

INSTRUCTIONS - procedures for achieving the objective

The Investigator candidate shall evaluate an investigative file, given all available file information, so that areas for further investigation are identified. Information shall be assessed, correlated and organized.

EXAMINER'S NOTE

The Investigator candidate will not be allowed to review the performance steps at the time of testing.

PREPARATION & EQUIPMENT

Investigative file

Reprinted with permission from NFPA 1033, *Professional Qualifications for Fire Investigator*, Copyright ©2013, National Fire Protection Association, Quincy, MA 02169. This reprinted material is not the complete and official position of the National Fire Protection Association on the referenced subject which is represented only by the standard in its entirety.

TEXAS COMMISSION ON FIRE PROTECTION
Fire Investigator
Performance Standards Evaluation

Candidate: _____ Notes: _____

Training Provider: _____

Test Site: _____

Examiner: _____

Fire Investigator	<u>TEST</u>		<u>RETEST</u>	
	S	U	S	U
Skill Number 19				
Evaluate the investigative file, given all available file information, so that areas for further investigation are identified, the relationship between gathered documents and information is interpreted, and corroborative evidence and information discrepancies are discovered. (1033-4.6.2)				
a) Assessed information				
b) Correlated information				
c) Organized information				
d) Performed skill in a safe and proficient manner				

S = Satisfactorily completed/performed

U = Unsatisfactorily performed/failed to meet objective or grading step

All steps of the skill objective are mandatory and must be scored as “Satisfactory” to pass the skill.

Reprinted with permission from NFPA 1033, *Professional Qualifications for Fire Investigator*, Copyright ©2013, National Fire Protection Association, Quincy, MA 02169. This reprinted material is not the complete and official position of the National Fire Protection Association on the referenced subject which is represented only by the standard in its entirety.

TEXAS COMMISSION ON FIRE PROTECTION
Fire Investigator
Performance Standards Evaluation

Examiner/Candidate Comments:

Examiner

Date

Re-Test Examiner

Date

Overall Skill Sheet Score	
Pass <input type="checkbox"/>	Fail <input type="checkbox"/>
Overall Skill Sheet Re-Test Score	
Pass <input type="checkbox"/>	Fail <input type="checkbox"/>

Reprinted with permission from NFPA 1033, *Professional Qualifications for Fire Investigator*, Copyright ©2013, National Fire Protection Association, Quincy, MA 02169. This reprinted material is not the complete and official position of the National Fire Protection Association on the referenced subject which is represented only by the standard in its entirety.

TEXAS COMMISSION ON FIRE PROTECTION

Fire Investigator

Performance Standards Evaluation

Skill Number 20

Coordinating Expert Resources

Subject: Post-Incident Investigation

NFPA 1033, 2014 edition, 4.6.3

Fire Investigator

OBJECTIVE

Coordinate expert resources, given the investigative file, reports, and documents, so that the expert's competencies are matched to the specific investigation needs, financial expenditures are justified, and utilization clearly furthers the investigative goals of determining cause or affixing responsibility. (4.6.3)

INSTRUCTIONS - procedures for achieving the objective

The Investigator candidate shall coordinate expert resources, given the investigative file, reports, and documents so that the expert's competencies are matched to the specific investigation needs, financial expenditures are justified, and demonstrate that use of the expert clearly furthers the investigation's goals.

EXAMINER'S NOTE

The Investigator candidate will not be allowed to review the performance steps at the time of testing.

PREPARATION & EQUIPMENT

Investigative file

Reports and documents

TEXAS COMMISSION ON FIRE PROTECTION
Fire Investigator
Performance Standards Evaluation

Candidate: _____ Notes: _____

Training Provider: _____

Test Site: _____

Examiner: _____

Fire Investigator	<u>TEST</u>		<u>RETEST</u>	
	S	U	S	U
Skill Number 20				
Coordinate expert resources, given the investigative file, reports, and documents, so that the expert's competencies are matched to the specific investigation needs, financial expenditures are justified, and utilization clearly furthers the investigative goals of determining cause or affixing responsibility. (1033-4.6.3)				
a) Verbally identified the need for specific experts				
b) Verbally identified resources for networking to identify experts				
c) Developed questions to determine the qualifications of experts				
d) Verbally justified costs for an expert witness				
e) Documented how the selected expert witnesses will be utilized to assist in the determination of causation or affixing responsibility				
f) Performed skill in a safe and proficient manner				

S = Satisfactorily completed/performed

U = Unsatisfactorily performed/failed to meet objective or grading step

All steps of the skill objective are mandatory and must be scored as "Satisfactory" to pass the skill.

Reprinted with permission from NFPA 1033, *Professional Qualifications for Fire Investigator*, Copyright ©2013, National Fire Protection Association, Quincy, MA 02169. This reprinted material is not the complete and official position of the National Fire Protection Association on the referenced subject which is represented only by the standard in its entirety.

TEXAS COMMISSION ON FIRE PROTECTION
Fire Investigator
Performance Standards Evaluation

Examiner/Candidate Comments:

Examiner

Date

Re-Test Examiner

Date

Overall Skill Sheet Score
Pass <input type="checkbox"/> Fail <input type="checkbox"/>
Overall Skill Sheet Re-Test Score
Pass <input type="checkbox"/> Fail <input type="checkbox"/>

Reprinted with permission from NFPA 1033, *Professional Qualifications for Fire Investigator*, Copyright ©2013, National Fire Protection Association, Quincy, MA 02169. This reprinted material is not the complete and official position of the National Fire Protection Association on the referenced subject which is represented only by the standard in its entirety.

TEXAS COMMISSION ON FIRE PROTECTION

Fire Investigator

Performance Standards Evaluation

Skill Number 21

Establishing Evidence as to Motive and/or Opportunity - Incendiary Fire

Subject: Post-Incident Investigation

NFPA 1033, 2014 edition, 4.6.4

Fire Investigator

OBJECTIVE

Establish evidence as to motive and/or opportunity, given an incendiary fire, so that the evidence is supported by documentation and meets the evidentiary requirements of the jurisdiction. (4.6.4)

INSTRUCTIONS - procedures for achieving the objective

The Investigator candidate shall establish motive and/or opportunity of an incendiary fire through the use of prudent and complete investigation files, determining if the evidence meets legal requirements.

EXAMINER'S NOTE

The Investigator candidate will not be allowed to review the performance steps at the time of testing.

PREPARATION & EQUIPMENT

A complete incendiary fire investigation file
Evidence log
Financial records

TEXAS COMMISSION ON FIRE PROTECTION
Fire Investigator
Performance Standards Evaluation

Candidate: _____ Notes: _____

Training Provider: _____

Test Site: _____

Examiner: _____

Fire Investigator	<u>TEST</u>		<u>RETEST</u>	
	S	U	S	U
Skill Number 21				
Establish evidence as to motive and/or opportunity, given an incendiary fire, so that the evidence is supported by documentation and meets the evidentiary requirements of the jurisdiction. (4.6.4)				
a) Reviewed provided materials				
b) Reviewed and verbalized that the financial records were analyzed for clues for a financial motive				
c) Determined and verbalized the motive and/or opportunity of the incendiary fire				
d) Verbally identified supporting documents that establish motive finding				
e) Verbally identified evidence used to determine motive				
f) Verbalized the legal value of evidence provided				

S = Satisfactorily completed/performed

U = Unsatisfactorily performed/failed to meet objective or grading step

All steps of the skill objective are mandatory and must be scored as “Satisfactory” to pass the skill.

Reprinted with permission from NFPA 1033, *Professional Qualifications for Fire Investigator*, Copyright ©2013, National Fire Protection Association, Quincy, MA 02169. This reprinted material is not the complete and official position of the National Fire Protection Association on the referenced subject which is represented only by the standard in its entirety.

TEXAS COMMISSION ON FIRE PROTECTION
Fire Investigator
Performance Standards Evaluation

Examiner/Candidate Comments:

Examiner

Date

Re-Test Examiner

Date

Overall Skill Sheet Score	
Pass <input type="checkbox"/>	Fail <input type="checkbox"/>
Overall Skill Sheet Re-Test Score	
Pass <input type="checkbox"/>	Fail <input type="checkbox"/>

Reprinted with permission from NFPA 1033, *Professional Qualifications for Fire Investigator*, Copyright ©2013, National Fire Protection Association, Quincy, MA 02169. This reprinted material is not the complete and official position of the National Fire Protection Association on the referenced subject which is represented only by the standard in its entirety.

TEXAS COMMISSION ON FIRE PROTECTION
Fire Investigator
Performance Standards Evaluation

Skill Number 22

Formulating an Opinion of the Person(s) and/or Product(s) Responsible for the Fire

Subject: Post-Incident Investigation

NFPA 1033, 2014 edition, 4.6.5

Fire Investigator

OBJECTIVE

Formulate an opinion concerning origin, cause, or responsibility for the fire, given all investigative findings, so that the opinion regarding origin, cause, or responsibility for a fire is supported by the data, facts, records, reports, documents, and evidence. (4.6.5)

INSTRUCTIONS - procedures for achieving the objective

The Investigator candidate shall formulate an opinion of the person(s) and/or product(s) responsible for the fire.

EXAMINER'S NOTE

The Investigator candidate will not be allowed to review the performance steps at the time of testing.

PREPARATION & EQUIPMENT

A complete fire investigation file including records, documents and evidence

Reprinted with permission from NFPA 1033, *Professional Qualifications for Fire Investigator*, Copyright ©2013, National Fire Protection Association, Quincy, MA 02169. This reprinted material is not the complete and official position of the National Fire Protection Association on the referenced subject which is represented only by the standard in its entirety.

TEXAS COMMISSION ON FIRE PROTECTION
Fire Investigator
 Performance Standards Evaluation

Candidate: _____ Notes: _____

Training Provider: _____

Test Site: _____

Examiner: _____

Fire Investigator	<u>TEST</u>		<u>RETEST</u>	
	S	U	S	U
Skill Number 22				
Formulate an opinion concerning origin, cause, or responsibility for the fire, given all investigative findings, so that the opinion regarding origin, cause, or responsibility for a fire is supported by the data, facts, records, reports, documents, and evidence. (1033-4.6.5)				
a) Formulated, supported and documented an opinion as to the person and/or product responsible for the fire				
b) The opinion regarding origin, cause, or responsibility for a fire is supported by the data, facts, records, reports, documents, and evidence				
c) Performed skill in a safe and proficient manner				

S = Satisfactorily completed/performed

U = Unsatisfactorily performed/failed to meet objective or grading step

All steps of the skill objective are mandatory and must be scored as "Satisfactory" to pass the skill.

Reprinted with permission from NFPA 1033, *Professional Qualifications for Fire Investigator*, Copyright ©2013, National Fire Protection Association, Quincy, MA 02169. This reprinted material is not the complete and official position of the National Fire Protection Association on the referenced subject which is represented only by the standard in its entirety.

TEXAS COMMISSION ON FIRE PROTECTION
Fire Investigator
Performance Standards Evaluation

Examiner/Candidate Comments:

Examiner

Date

Re-Test Examiner

Date

Overall Skill Sheet Score	
Pass <input type="checkbox"/>	Fail <input type="checkbox"/>
Overall Skill Sheet Re-Test Score	
Pass <input type="checkbox"/>	Fail <input type="checkbox"/>

Reprinted with permission from NFPA 1033, *Professional Qualifications for Fire Investigator*, Copyright ©2013, National Fire Protection Association, Quincy, MA 02169. This reprinted material is not the complete and official position of the National Fire Protection Association on the referenced subject which is represented only by the standard in its entirety.

TEXAS COMMISSION ON FIRE PROTECTION
Fire Investigator
Performance Standards Evaluation

Skill Number 23
Preparing a Written Investigation Report

Subject: Presentations

NFPA 1033, 2014 edition, 4.7.1

Fire Investigator

OBJECTIVE

Prepare a written report, given investigative findings, documentation, and a specific audience, so that the report accurately reflects the investigative findings, is concise, expresses the investigator's opinion, contains facts and data that the investigator relies on in rendering an opinion, contains the reasoning of the investigator by which each opinion was reached, and meets the needs or requirements of the intended audience(s). (4.7.1)

INSTRUCTIONS - procedures for achieving the objective

The Investigator candidate shall write an initial investigation report, including an opinion as to the cause of the fire.

EXAMINER'S NOTE

The Investigator candidate will not be allowed to review the performance steps at the time of testing.

PREPARATION & EQUIPMENT

Investigation findings
Documentation
An identified audience
Forms
Note pad

Reprinted with permission from NFPA 1033, *Professional Qualifications for Fire Investigator*, Copyright ©2013, National Fire Protection Association, Quincy, MA 02169. This reprinted material is not the complete and official position of the National Fire Protection Association on the referenced subject which is represented only by the standard in its entirety.

TEXAS COMMISSION ON FIRE PROTECTION
Fire Investigator
Performance Standards Evaluation

Candidate: _____ Notes: _____

Training Provider: _____

Test Site: _____

Examiner: _____

Fire Investigator	<u>TEST</u>		<u>RETEST</u>	
	S	U	S	U
Skill Number 23				
Prepare a written report, given investigative findings, documentation, and a specific audience, so that the report accurately reflects the investigative findings, is concise, expresses the investigator's opinion, contains facts and data that the investigator relies on in rendering an opinion, contains the reasoning of the investigator by which each opinion was reached, and meets the needs or requirements of the intended audience(s). (1033-4.7.1)				
a) Analyzed the provided investigation information and incident reports				
b) Wrote initial investigation report using provided materials				
c) Included opinion of fire cause				
d) Reviewed the report for grammar and accuracy				
e) Verbally expressed the reader's needs or requirements				
f) Performed skill in a safe and proficient manner				

S = Satisfactorily completed/performed

U = Unsatisfactorily performed/failed to meet objective or grading step

All steps of the skill objective are mandatory and must be scored as "Satisfactory" to pass the skill.

Reprinted with permission from NFPA 1033, *Professional Qualifications for Fire Investigator*, Copyright ©2013, National Fire Protection Association, Quincy, MA 02169. This reprinted material is not the complete and official position of the National Fire Protection Association on the referenced subject which is represented only by the standard in its entirety.

TEXAS COMMISSION ON FIRE PROTECTION
Fire Investigator
Performance Standards Evaluation

Examiner/Candidate Comments:

Examiner

Date

Re-Test Examiner

Date

Overall Skill Sheet Score
Pass <input type="checkbox"/> Fail <input type="checkbox"/>
Overall Skill Sheet Re-Test Score
Pass <input type="checkbox"/> Fail <input type="checkbox"/>

Reprinted with permission from NFPA 1033, *Professional Qualifications for Fire Investigator*, Copyright ©2013, National Fire Protection Association, Quincy, MA 02169. This reprinted material is not the complete and official position of the National Fire Protection Association on the referenced subject which is represented only by the standard in its entirety.

TEXAS COMMISSION ON FIRE PROTECTION

Fire Investigator

Performance Standards Evaluation

Skill Number 24

Verbally Expressing Investigative Findings

Subject: Presentations

NFPA 1033, 2014 edition, 4.7.2

Fire Investigator

OBJECTIVE

Express investigative findings verbally, given investigative findings, notes, a time allotment, and a specific audience, so that the information is accurate, the presentation is completed within the allotted time, and the presentation includes only need-to-know information for the intended audience. (4.7.2)

INSTRUCTIONS - procedures for achieving the objective

The Investigator candidate shall review and verbally present an investigation report without error to a selected audience.

EXAMINER'S NOTE

The Investigator candidate will not be allowed to review the performance steps at the time of testing.

PREPARATION & EQUIPMENT

Investigation report findings

Notes

An identified audience (i.e., prosecutor)

TEXAS COMMISSION ON FIRE PROTECTION
Fire Investigator
Performance Standards Evaluation

Candidate: _____ Notes: _____

Training Provider: _____

Test Site: _____

Examiner: _____

Fire Investigator	<u>TEST</u>		<u>RETEST</u>	
	S	U	S	U
Skill Number 24				
Express investigative findings verbally, given investigative findings, notes, a time allotment, and a specific audience, so that the information is accurate, the presentation is completed within the allotted time, and the presentation includes only need-to-know information for the intended audience. (1033-4.7.2)				
a) Identified the audience's needs				
b) Verbally presented the report information and correlated findings				
c) Answered follow-up questions from the audience				
d) Performed skill in a safe and proficient manner				

S = Satisfactorily completed/performed

U = Unsatisfactorily performed/failed to meet objective or grading step

All steps of the skill objective are mandatory and must be scored as "Satisfactory" to pass the skill.

Reprinted with permission from NFPA 1033, *Professional Qualifications for Fire Investigator*, Copyright ©2013, National Fire Protection Association, Quincy, MA 02169. This reprinted material is not the complete and official position of the National Fire Protection Association on the referenced subject which is represented only by the standard in its entirety.

TEXAS COMMISSION ON FIRE PROTECTION
Fire Investigator
Performance Standards Evaluation

Examiner/Candidate Comments:

Examiner

Date

Re-Test Examiner

Date

Overall Skill Sheet Score	
Pass <input type="checkbox"/>	Fail <input type="checkbox"/>
Overall Skill Sheet Re-Test Score	
Pass <input type="checkbox"/>	Fail <input type="checkbox"/>

Reprinted with permission from NFPA 1033, *Professional Qualifications for Fire Investigator*, Copyright ©2013, National Fire Protection Association, Quincy, MA 02169. This reprinted material is not the complete and official position of the National Fire Protection Association on the referenced subject which is represented only by the standard in its entirety.

TEXAS COMMISSION ON FIRE PROTECTION

Fire Investigator

Performance Standards Evaluation

Skill Number 25

Testifying During Legal Proceedings

Subject: Presentations

NFPA 1033, 2014 edition, 4.7.3

Fire Investigator

OBJECTIVE

Testify during legal proceedings, given investigative findings, contents of reports, and consultation with legal counsel, so that all pertinent investigative information and evidence are presented clearly and accurately and the investigator's demeanor and attire are appropriate to the proceedings. (4.7.3)

INSTRUCTIONS - procedures for achieving the objective

Investigator candidate shall testify and be cross-examined in a mock courtroom.

EXAMINER'S NOTE

The Investigator candidate will not be allowed to review the performance steps at the time of testing.

PREPARATION & EQUIPMENT

Investigative findings

30 minutes to review information

Consultation with prosecution legal counsel

Reprinted with permission from NFPA 1033, *Professional Qualifications for Fire Investigator*, Copyright ©2013, National Fire Protection Association, Quincy, MA 02169. This reprinted material is not the complete and official position of the National Fire Protection Association on the referenced subject which is represented only by the standard in its entirety.

TEXAS COMMISSION ON FIRE PROTECTION
Fire Investigator
 Performance Standards Evaluation

Candidate: _____ Notes: _____

Training Provider: _____

Test Site: _____

Examiner: _____

Fire Investigator	<u>TEST</u>		<u>RETEST</u>	
	S	U	S	U
Skill Number 25				
Testify during legal proceedings, given investigative findings, contents of reports, and consultation with legal counsel, so that all pertinent investigative information and evidence are presented clearly and accurately and the investigator's demeanor and attire are appropriate to the proceedings. (1033-4.7.3)				
a) Reviewed provided information within thirty minutes				
b) Asked questions of the prosecutor before testifying				
c) Answered questions from the prosecutor before testifying				
d) Differentiated between facts and opinions				
e) Testified in court to prosecutor's questions				
f) Testified in court to cross-examination by defense counsel				
g) Demonstrated proper etiquette during proceedings				
h) Performed skill in a safe and proficient manner				

S = Satisfactorily completed/performed

U = Unsatisfactorily performed/failed to meet objective or grading step

All steps of the skill objective are mandatory and must be scored as "Satisfactory" to pass the skill.

Reprinted with permission from NFPA 1033, *Professional Qualifications for Fire Investigator*, Copyright ©2013, National Fire Protection Association, Quincy, MA 02169. This reprinted material is not the complete and official position of the National Fire Protection Association on the referenced subject which is represented only by the standard in its entirety.

TEXAS COMMISSION ON FIRE PROTECTION
Fire Investigator
Performance Standards Evaluation

Examiner/Candidate Comments:

Examiner

Date

Re-Test Examiner

Date

Overall Skill Sheet Score	
Pass <input type="checkbox"/>	Fail <input type="checkbox"/>
Overall Skill Sheet Re-Test Score	
Pass <input type="checkbox"/>	Fail <input type="checkbox"/>

Reprinted with permission from NFPA 1033, *Professional Qualifications for Fire Investigator*, Copyright ©2013, National Fire Protection Association, Quincy, MA 02169. This reprinted material is not the complete and official position of the National Fire Protection Association on the referenced subject which is represented only by the standard in its entirety.