

PERFORMANCE SKILLS MANUAL

CHAPTER FIVE FIRE INVESTIGATOR

NFPA 1033 – 2022 Edition

Effective June 1, 2025



Texas Commission on Fire Protection
P.O. Box 2286 Austin, Texas 78768-2286 (512) 936-3838

INSTRUCTION SHEET FIRE INVESTIGATOR PERFORMANCE SKILLS

Format

Each skill contains its own skill sheet, is evaluated independently, and is based on the JPRs in National Fire Protection Association (NFPA) 1033, *Standard for Professional Qualifications for Fire Investigator*, 2022 edition.

For skill sheets that do not contain time constraints, the Course Instructor should specify time constraints as necessary.

Scoring Method

The scoring method is satisfactory (S) or unsatisfactory (U) for each step of the skill objective, and a Pass or Fail for each individual skill section. In order to successfully pass an individual skill section, the Fire Investigator candidate must receive satisfactory scores in all the steps of the skill objective. In order to receive an overall Pass on the skill sheet, the Fire Investigator candidate must receive a passing score for all individual skill sections.

Any unsatisfactory or individual skill failure shall require the examiner to explain the reason for the failure in written form in the comments section of the skill sheet.

Preparation and Equipment

For optimal learning, scenario-based training and role-playing is recommended; however, based on departmental needs certain activities may be simulated by other means.

EQUIPMENT LIST FIRE INVESTIGATOR PERFORMANCE SKILLS

- Fire ground (actual or simulated)
 - Structure
 - Video
 - PowerPoint
 - Slides
 - With evidence of an explosion
 - Simulated victim or fatality
 - Vehicle
 - Building systems
- Six items of potential evidence
- Burned items
- Protective clothing (Appropriate safety equipment)
 - Boots
 - Gloves
 - Hard hat
 - Safety glasses
 - SCBA (if IDLH atmosphere)
- Standard equipment and tools
- Model evidence policy
- Marking devices
- Evidence collection containers
- Evidence tags or labels
- Chain of custody forms
- Evidence disposal forms
- Incendiary investigation file including:
 - Incident information
 - Interview Information
 - Photos
 - Suppression report
 - Conflicting information
 - Expert witness backgrounds
 - Competencies
 - Fee schedules
 - Authorization from the prosecutor to include the candidate's opinion in the report

EQUIPMENT LIST (continued)

- Witness statements
- Standard crime lab analysis form
- Floor plan map
- Pre fire plans
- Inspection reports
- Fire report (TEXFIRS)
- Fire scene tape
- Measuring device
- Pencil/pen
- Note pad
- Photo log
- Camera with flash, and accessories
 - 35 mm
 - Digital
 - Film
- Interview room setting
- Interview forms
- Interview transcripts
- DOT *Emergency Response Guidebook*, current edition
- Various placards
- Scenario involving identified hazardous materials
- Additional personnel if needed

**SKILLS LIST
FIRE INVESTIGATOR PERFORMANCE SKILLS**

Subject	Skill No.	Functional Name	NFPA 1033 JPR #
Scene Examination	1	Securing the Fire Ground	4.2.1
Scene Examination	2	Conducting an Exterior Survey	4.2.2
Scene Examination	3	Conducting an Interior Survey	4.2.3
Scene Examination	4	Interpret Fire Patterns in a Vehicle	4.2.4
Scene Examination	5	Interpret and Analyze Fire Patterns	4.2.4, 4.2.5
Scene Examination	6	Examining and Removing Fire Debris	4.2.6, 4.2.9
Scene Examination	7	Reconstructing the Area of Origin	4.2.7
Scene Examination	8	Inspecting the Performance of Building Systems	4.2.8
Documenting the Scene	9	Diagramming the Scene	4.3.1
Documenting the Scene	10	Photographically Documenting the Scene	4.3.2
Documenting the Scene	11	Constructing Investigative Notes	4.3.3
Evidence Collection/Preservation	12	Utilizing Proper Procedures for Managing Victims and Fatalities	4.4.1, 4.4.2, 4.4.3
Evidence Collection/Preservation	13	Maintaining a Chain of Custody	4.4.4
Evidence Collection/Preservation	14	Disposing of Evidence	4.4.5
Interview	15	Developing an Interview Plan	4.5.1
Interview	16	Conducting Interviews	4.5.2
Interview	17	Evaluating Interview Information	4.5.3
Post-Incident Investigation	18	Gathering Reports and Records	4.6.1
Post-Incident Investigation	19	Evaluating the Investigative File	4.6.2
Post-Incident Investigation	20	Coordinating Expert Resources	4.6.3
Post-Incident Investigation	21	Establishing Evidence as to Motive and/or Opportunity - Incendiary Fire	4.6.4
Post-Incident Investigation	22	Formulating an Opinion of the Person(s) and/or Product(s) Responsible for the Fire	4.6.5
Presentations	23	Preparing a Written Investigation Report	4.7.1
Presentations	24	Verbally Expressing Investigative Findings	4.7.2
Presentations	25	Testifying During Legal Proceedings	4.7.3

PERFORMANCE SKILL SHEETS

FIRE INVESTIGATOR

TEXAS COMMISSION ON FIRE PROTECTION
Fire Investigator
Performance Standards Evaluation

Skill 1
Securing the Fire Ground

NFPA 1033, 2022 edition
4.2.1

Scene Examination

OBJECTIVE

Secure the fire ground, given marking devices, sufficient personnel, and special tools and equipment, so that unauthorized persons can recognize the perimeters of the investigative scene and are kept from restricted areas and all evidence or potential evidence is protected from damage or destruction. (4.2.1)

INSTRUCTIONS - procedures for achieving the objective

The Investigator candidate shall secure the fire ground to protect evidence and restrict access.

EXAMINER'S NOTE

The Investigator candidate will not be allowed to review the performance steps at the time of testing.

The fire ground scene may be physically simulated; however, the investigator candidate must perform each step of the required skill in the presence of the field examiner.

PREPARATION & EQUIPMENT

- Fire ground (actual or simulated) Marking devices
- Appropriate safety equipment

Reprinted with permission from NFPA 1033, *Professional Qualifications for Fire Investigator*, Copyright ©2022, National Fire Protection Association, Quincy, MA 02169. This reprinted material is not the complete and official position of the National Fire Protection Association on the referenced subject which is represented only by the standard in its entirety.

TEXAS COMMISSION ON FIRE PROTECTION
Fire Investigator
Performance Standards Evaluation

Candidate: _____

Training Provider: _____

Test Site: _____

Examiner(s): _____

SKILL 1				
Securing the Fire Ground				
Secure the fire ground, given marking devices, sufficient personnel, and special tools and equipment, so that unauthorized persons can recognize the perimeters of the investigative scene and are kept from restricted areas and all evidence or potential evidence is protected from damage or destruction. (4.2.1)				
	<u>TEST</u>		<u>RETEST</u>	
The Candidate:	S	U	S	U
a) Located general area of fire origin				
b) Marked items of potential evidence				
c) Verbally described the importance of fire scene security				
d) Placed scene restriction marking devices around the origin area and/or potential evidence items				
e) Verbally described evidence preservation				
f) Verbally described issues relating to spoliation				
g) Prevented unauthorized entry				
h) Performed skill in a safe and proficient manner				

S = Satisfactorily completed/performed

U = Unsatisfactorily performed/failed to meet objective or grading step

All steps of the skill objective are mandatory and must be scored as “Satisfactory” to pass the skill.

Reprinted with permission from NFPA 1033, *Professional Qualifications for Fire Investigator*, Copyright ©2022, National Fire Protection Association, Quincy, MA 02169. This reprinted material is not the complete and official position of the National Fire Protection Association on the referenced subject which is represented only by the standard in its entirety.

TEXAS COMMISSION ON FIRE PROTECTION
Fire Investigator
Performance Standards Evaluation

Examiner/Candidate Comments:

 Certifying Examiner

 Date

 Re-Test Certifying Examiner

 Date

Overall Skill Test Score			
Pass:		Fail:	
Overall Skill Re-Test Score			
Pass:		Fail:	

Reprinted with permission from NFPA 1033, *Professional Qualifications for Fire Investigator*, Copyright ©2022, National Fire Protection Association, Quincy, MA 02169. This reprinted material is not the complete and official position of the National Fire Protection Association on the referenced subject which is represented only by the standard in its entirety.

TEXAS COMMISSION ON FIRE PROTECTION
Fire Investigator
Performance Standards Evaluation

Skill 2
Conducting an Exterior Survey

NFPA 1033, 2022 edition
4.2.2

Scene Examination

OBJECTIVE

Conduct an exterior survey, given standard equipment and tools, so that evidence is identified and preserved, fire damage is interpreted, hazards are identified to avoid injuries, accessibility to the property is determined, and all potential means of ingress and egress are discovered. (4.2.2)

INSTRUCTIONS - procedures for achieving the objective

The Investigator candidate, while keeping safety in mind, shall conduct a 360-degree exterior survey of the scene. The Investigator candidate shall identify entry/exit points, items of potential evidence, and post fire indicators.

EXAMINER'S NOTE

The Investigator candidate will not be allowed to review the performance steps at the time of testing.

The fire ground scene may be physically simulated; however, the investigator candidate must perform each step of the required skill in the presence of the field examiner.

PREPARATION & EQUIPMENT

- Fire ground (actual or simulated)
- Note pad
- Camera
- Appropriate safety equipment

Reprinted with permission from NFPA 1033, *Professional Qualifications for Fire Investigator*, Copyright ©2022, National Fire Protection Association, Quincy, MA 02169. This reprinted material is not the complete and official position of the National Fire Protection Association on the referenced subject which is represented only by the standard in its entirety.

TEXAS COMMISSION ON FIRE PROTECTION
Fire Investigator
Performance Standards Evaluation

Candidate: _____

Training Provider: _____

Test Site: _____

Examiner(s): _____

SKILL 2				
Conducting an Exterior Survey				
Conduct an exterior survey, given standard equipment and tools, so that evidence is identified and preserved, fire damage is interpreted, hazards are identified to avoid injuries, accessibility to the property is determined, and all potential means of ingress and egress are discovered. (4.2.2)				
	<u>TEST</u>		<u>RETEST</u>	
The Candidate:	S	U	S	U
a) Secured the fire ground				
b) Verbally described the building construction and condition				
c) Conducted an exterior 360-degree survey around the fire ground				
d) Documented observations of the effects of fire suppression				
e) Documented observations of the effects of fire on fire behavior and spread, evidence preservation methods and fire patterns				
f) Marked entry/exit points				
g) Performed skill in a safe and proficient manner				

S = Satisfactorily completed/performed

U = Unsatisfactorily performed/failed to meet objective or grading step

All steps of the skill objective are mandatory and must be scored as “Satisfactory” to pass the skill.

Reprinted with permission from NFPA 1033, *Professional Qualifications for Fire Investigator*, Copyright ©2022, National Fire Protection Association, Quincy, MA 02169. This reprinted material is not the complete and official position of the National Fire Protection Association on the referenced subject which is represented only by the standard in its entirety.

TEXAS COMMISSION ON FIRE PROTECTION
Fire Investigator
Performance Standards Evaluation

Examiner/Candidate Comments:

 Certifying Examiner

 Date

 Re-Test Certifying Examiner

 Date

Overall Skill Test Score			
Pass:		Fail:	
Overall Skill Re-Test Score			
Pass:		Fail:	

Reprinted with permission from NFPA 1033, *Professional Qualifications for Fire Investigator*, Copyright ©2022, National Fire Protection Association, Quincy, MA 02169. This reprinted material is not the complete and official position of the National Fire Protection Association on the referenced subject which is represented only by the standard in its entirety.

TEXAS COMMISSION ON FIRE PROTECTION
Fire Investigator
Performance Standards Evaluation

Skill 3
Conducting an Interior Survey

NFPA 1033, 2022 edition
4.2.3

Scene Examination

OBJECTIVE

Conduct an interior survey, given standard equipment and tools, so that areas of potential evidentiary value requiring further examination are identified and preserved, the evidentiary value of contents is determined, and hazards are identified in order to avoid injuries. (4.2.3)

INSTRUCTIONS - procedures for achieving the objective

The Investigator candidate, while keeping safety in mind, shall conduct a 360-degree interior survey of the fire scene. The Investigator candidate shall identify entry/exit points, items of potential evidence, and post fire indicators.

EXAMINER'S NOTE

The Investigator candidate will not be allowed to review the performance steps at the time of testing.

The fire ground scene may be physically simulated; however, the investigator candidate must perform each step of the required skill in the presence of the field examiner.

PREPARATION & EQUIPMENT

- Fire ground (actual or simulated)
- Note pad
- Standard equipment and tools
- Appropriate safety equipment
- Camera

Reprinted with permission from NFPA 1033, *Professional Qualifications for Fire Investigator*, Copyright ©2022, National Fire Protection Association, Quincy, MA 02169. This reprinted material is not the complete and official position of the National Fire Protection Association on the referenced subject which is represented only by the standard in its entirety.

TEXAS COMMISSION ON FIRE PROTECTION
Fire Investigator
Performance Standards Evaluation

Candidate: _____

Training Provider: _____

Test Site: _____

Examiner(s): _____

SKILL 3				
Conducting an Interior Survey				
Conduct an interior survey, given standard equipment and tools, so that areas of potential evidentiary value requiring further examination are identified and preserved, the evidentiary value of contents is determined, and hazards are identified in order to avoid injuries. (4.2.3)				
	<u>TEST</u>		<u>RETEST</u>	
The Candidate:	S	U	S	U
a) Verbally described the structural condition and interior finish				
b) Conducted a 360-degree interior survey of the fire scene				
c) Documented observations of the effects of fire suppression				
d) Documented observations of the effects of fire on fire behavior and spread, evidence preservation methods and fire patterns				
e) Marked entry/exit points				
f) Evaluated protected areas to determine the presence and/or absence of contents				
g) Performed skill in a safe and proficient manner				

S = Satisfactorily completed/performed

U = Unsatisfactorily performed/failed to meet objective or grading step

All steps of the skill objective are mandatory and must be scored as “Satisfactory” to pass the skill.

Reprinted with permission from NFPA 1033, *Professional Qualifications for Fire Investigator*, Copyright ©2022, National Fire Protection Association, Quincy, MA 02169. This reprinted material is not the complete and official position of the National Fire Protection Association on the referenced subject which is represented only by the standard in its entirety.

TEXAS COMMISSION ON FIRE PROTECTION
Fire Investigator
Performance Standards Evaluation

Examiner/Candidate Comments:

 Certifying Examiner

 Date

 Re-Test Certifying Examiner

 Date

Overall Skill Test Score			
Pass:		Fail:	
Overall Skill Re-Test Score			
Pass:		Fail:	

Reprinted with permission from NFPA 1033, *Professional Qualifications for Fire Investigator*, Copyright ©2022, National Fire Protection Association, Quincy, MA 02169. This reprinted material is not the complete and official position of the National Fire Protection Association on the referenced subject which is represented only by the standard in its entirety.

TEXAS COMMISSION ON FIRE PROTECTION
Fire Investigator
Performance Standards Evaluation

Skill 4
Interpret Fire Patterns in a Vehicle

NFPA 1033, 2022 edition
4.2.4

Scene Examination

OBJECTIVE

Interpret and analyze fire patterns, given standard equipment and tools and some structural or content remains, so that each pattern is identified and analyzed with respect to the burning characteristics of the material involved, the stage of fire development, the effects of ventilation within the context of the scene, the relationship with all patterns observed, and the understanding of the methods of heat transfer that led to the formation of the patterns identified and analyzed, and the sequence in which the patterns were produced is determined. (4.2.4)

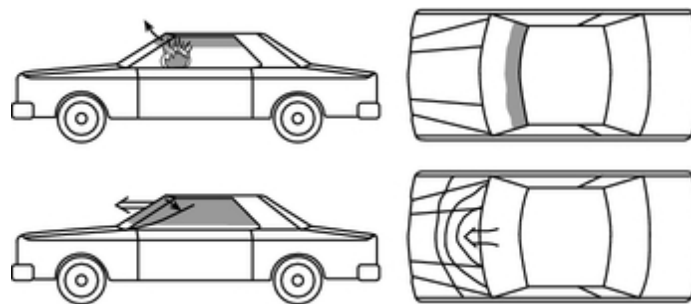

INSTRUCTIONS - procedures for achieving the objective

The Investigator candidate shall observe a vehicle fire scene and interpret fire patterns, given standard equipment and tools and a vehicle, so that each individual pattern is evaluated with respect to the burning characteristics of the material involved.

EXAMINER'S NOTE

The Investigator candidate will not be allowed to review the performance steps at the time of testing.

The fire ground scene may be physically simulated; however, the investigator candidate must perform each step of the required skill in the presence of the field examiner.

Reprinted with permission from NFPA 1033, *Professional Qualifications for Fire Investigator*, Copyright ©2022, National Fire Protection Association, Quincy, MA 02169. This reprinted material is not the complete and official position of the National Fire Protection Association on the referenced subject which is represented only by the standard in its entirety.

TEXAS COMMISSION ON FIRE PROTECTION
Fire Investigator
Performance Standards Evaluation

PREPARATION & EQUIPMENT

- Vehicle fire ground (actual or simulated)
- Note pad
- Standard equipment and tools
- Appropriate safety equipment

Reprinted with permission from NFPA 1033, *Professional Qualifications for Fire Investigator*, Copyright ©2022, National Fire Protection Association, Quincy, MA 02169. This reprinted material is not the complete and official position of the National Fire Protection Association on the referenced subject which is represented only by the standard in its entirety.

TEXAS COMMISSION ON FIRE PROTECTION
Fire Investigator
Performance Standards Evaluation

Candidate: _____

Training Provider: _____

Test Site: _____

Examiner(s): _____

SKILL 4				
Interpret Fire Patterns in a Vehicle				
Interpret and analyze fire patterns, given standard equipment and tools and some structural or content remains, so that each pattern is identified and analyzed with respect to the burning characteristics of the material involved, the stage of fire development, the effects of ventilation within the context of the scene, the relationship with all patterns observed, and the understanding of the methods of heat transfer that led to the formation of the patterns identified and analyzed, and the sequence in which the patterns were produced is determined. (4.2.4)				
	<u>TEST</u>		<u>RETEST</u>	
The Candidate:	S	U	S	U
a) Interpreted and documented fire patterns and heat transfer mechanisms on different types of materials				
b) Determined an area of origin in or near the vehicle				
c) Examined the engine compartment, the passenger compartment or interior, and the cargo compartment				
d) Interpreted and documented signs of fire development				
e) Performed skill in a safe and proficient manner				

S = Satisfactorily completed/performed

U = Unsatisfactorily performed/failed to meet objective or grading step

All steps of the skill objective are mandatory and must be scored as “Satisfactory” to pass the skill.

Reprinted with permission from NFPA 1033, *Professional Qualifications for Fire Investigator*, Copyright ©2022, National Fire Protection Association, Quincy, MA 02169. This reprinted material is not the complete and official position of the National Fire Protection Association on the referenced subject which is represented only by the standard in its entirety.

TEXAS COMMISSION ON FIRE PROTECTION
Fire Investigator
Performance Standards Evaluation

Examiner/Candidate Comments:

 Certifying Examiner

 Date

 Re-Test Certifying Examiner

 Date

Overall Skill Test Score			
Pass:		Fail:	
Overall Skill Re-Test Score			
Pass:		Fail:	

Reprinted with permission from NFPA 1033, *Professional Qualifications for Fire Investigator*, Copyright ©2022, National Fire Protection Association, Quincy, MA 02169. This reprinted material is not the complete and official position of the National Fire Protection Association on the referenced subject which is represented only by the standard in its entirety.

TEXAS COMMISSION ON FIRE PROTECTION
Fire Investigator
Performance Standards Evaluation

Skill 5

Interpret and Analyze Fire Patterns

NFPA 1033, 2022 edition
4.2.4, 4.2.5

Scene Examination

OBJECTIVE

Interpret and analyze fire patterns, given standard equipment and tools and some structural or content remains, so that each pattern is identified and analyzed with respect to the burning characteristics of the material involved, the stage of fire development, the effects of ventilation within the context of the scene, the relationship with all patterns observed, and the understanding of the methods of heat transfer that led to the formation of the patterns identified and analyzed, and the sequence in which the patterns were produced is determined. (4.2.4)

Interpret and analyze fire patterns, given standard equipment and tools and some structural or content remains, so that fire development, fire spread, and the sequence in which fire patterns were developed (i.e., sequential pattern analysis) are determined; methods and effects of suppression are analyzed; fire patterns and effects indicating a hypothetical area or areas of origin are recognized and tested; false or refuted hypothetical areas of origin are eliminated; and all fire patterns are tested against the data, such that the area(s) of origin is correctly identified. (4.2.5)

INSTRUCTIONS - procedures for achieving the objective

The Investigator candidate shall observe a fire scene and interpret and analyze fire patterns, given standard equipment and tools and some structural or content remains, so that fire development, fire spread, and the sequence in which fire patterns were developed are determined; methods and effects of suppression are analyzed; fire pattern and effects indicating hypothetical area or areas of origin are recognized and tested; false or refuted hypothetical areas of origin are eliminated; and all fire patterns are tested against the data, such that the area(s) of origin is correctly identified. Also, each individual pattern is evaluated with respect to the burning characteristics of the material involved.

EXAMINER'S NOTE

The Investigator candidate will not be allowed to review the performance steps at the time of testing.

The fire ground scene may be physically simulated; however, the investigator candidate must perform each step of the required skill in the presence of the field examiner.

Reprinted with permission from NFPA 1033, *Professional Qualifications for Fire Investigator*, Copyright ©2022, National Fire Protection Association, Quincy, MA 02169. This reprinted material is not the complete and official position of the National Fire Protection Association on the referenced subject which is represented only by the standard in its entirety.

TEXAS COMMISSION ON FIRE PROTECTION
Fire Investigator
Performance Standards Evaluation

PREPARATION & EQUIPMENT

- Fire ground (actual or simulated)
- Note pad
- Camera
- Standard equipment and tools
- Appropriate safety equipment

Reprinted with permission from NFPA 1033, *Professional Qualifications for Fire Investigator*, Copyright ©2022, National Fire Protection Association, Quincy, MA 02169. This reprinted material is not the complete and official position of the National Fire Protection Association on the referenced subject which is represented only by the standard in its entirety.

TEXAS COMMISSION ON FIRE PROTECTION
Fire Investigator
Performance Standards Evaluation

Candidate: _____

Training Provider: _____

Test Site: _____

Examiner(s): _____

SKILL 5				
Interpret and Analyze Fire Patterns				
<p>Interpret and analyze fire patterns, given standard equipment and tools and some structural or content remains, so that each pattern is identified and analyzed with respect to the burning characteristics of the material involved, the stage of fire development, the effects of ventilation within the context of the scene, the relationship with all patterns observed, and the understanding of the methods of heat transfer that led to the formation of the patterns identified and analyzed, and the sequence in which the patterns were produced is determined. (4.2.4)</p>				
<p>Interpret and analyze fire patterns, given standard equipment and tools and some structural or content remains, so that fire development, fire spread, and the sequence in which fire patterns were developed (i.e., sequential pattern analysis) are determined; methods and effects of suppression are analyzed; fire patterns and effects indicating a hypothetical area or areas of origin are recognized and tested; false or refuted hypothetical areas of origin are eliminated; and all fire patterns are tested against the data, such that the area(s) of origin is correctly identified. (4.2.5)</p>				
	<u>TEST</u>		<u>RETEST</u>	
The Candidate:	S	U	S	U
a) Interpreted and analyzed fire patterns and heat transfer mechanisms on different materials with consideration given to heat release rate, form and ignitibility				
b) Verbally distinguished impact of different types of fuel loads				
c) Evaluated and documented fuel trails				
d) Documented the analyzed and synthesized information				
e) Interpreted and documented signs of fire development and fire dynamics				
f) Performed skill in a safe and proficient manner				

Reprinted with permission from NFPA 1033, *Professional Qualifications for Fire Investigator*, Copyright ©2022, National Fire Protection Association, Quincy, MA 02169. This reprinted material is not the complete and official position of the National Fire Protection Association on the referenced subject which is represented only by the standard in its entirety.

TEXAS COMMISSION ON FIRE PROTECTION
Fire Investigator
Performance Standards Evaluation

S = Satisfactorily completed/performed

U = Unsatisfactorily performed/failed to meet objective or grading step

All steps of the skill objective are mandatory and must be scored as “Satisfactory” to pass the skill.

Examiner/Candidate Comments:

 Certifying Examiner

 Date

 Re-Test Certifying Examiner

 Date

Overall Skill Test Score			
Pass:		Fail:	
Overall Skill Re-Test Score			
Pass:		Fail:	

Reprinted with permission from NFPA 1033, *Professional Qualifications for Fire Investigator*, Copyright ©2022, National Fire Protection Association, Quincy, MA 02169. This reprinted material is not the complete and official position of the National Fire Protection Association on the referenced subject which is represented only by the standard in its entirety.

TEXAS COMMISSION ON FIRE PROTECTION
Fire Investigator
Performance Standards Evaluation

Skill 6
Examining and Removing Fire Debris

NFPA 1033, 2022 edition
4.2.6, 4.2.9

Scene Examination

OBJECTIVE

Examine and remove fire debris, given standard or, if necessary, special equipment and tools, so that fire patterns and fire effects concealed by debris are discovered and analyzed; all debris within the potential areas(s) of origin is checked for fire cause evidence, potential ignition source(s) is identified, and evidence is preserved without investigator-inflicted damage or contamination. (4.2.6)

Discriminate the effects of explosions from other types of damage, given standard equipment and tools, so that an explosion is identified, and its evidence is preserved. (4.2.9)

INSTRUCTIONS - procedures for achieving the objective

The Investigator candidate shall, while wearing proper PPE, examine and remove fire debris from a scene. The Investigator candidate shall check all of the debris and the surrounding area for fire cause evidence, including evidence of an explosion. The Investigator candidate shall identify the ignition source(s), determine the cause of the fire, and preserve all evidence properly.

EXAMINER'S NOTE

The Investigator candidate will not be allowed to review the performance steps at the time of testing. Evidence of an explosion must be included so that the candidate's ability to discriminate the effects of an explosion, identify the explosion, and preserve the evidence of the explosion can all be evaluated. Evidence of an explosion might actually be in the debris or surrounding materials at a scene, or it could be photographic evidence presented from a case file.

The fire ground scene may be physically simulated; however, the investigator candidate must perform each step of the required skill in the presence of the field examiner.

PREPARATION & EQUIPMENT

- Fire ground with evidence of an explosion (actual or simulated)
- Standard and special equipment and tools
- Evidence collection containers
- Appropriate safety equipment

Reprinted with permission from NFPA 1033, *Professional Qualifications for Fire Investigator*, Copyright ©2022, National Fire Protection Association, Quincy, MA 02169. This reprinted material is not the complete and official position of the National Fire Protection Association on the referenced subject which is represented only by the standard in its entirety.

TEXAS COMMISSION ON FIRE PROTECTION
Fire Investigator
Performance Standards Evaluation

Candidate: _____

Training Provider: _____

Test Site: _____

Examiner(s): _____

SKILL 6				
Examining and Removing Fire Debris				
<p>Examine and remove fire debris, given standard or, if necessary, special equipment and tools, so that fire patterns and fire effects concealed by debris are discovered and analyzed; all debris within the potential area(s) of origin is checked for fire cause evidence, potential ignition source(s) is identified, and evidence is preserved without investigator-inflicted damage or contamination. (4.2.6)</p> <p>Discriminate the effects of explosions from other types of damage, given standard equipment and tools, so that an explosion is identified, and its evidence is preserved. (4.2.9)</p>				
	TEST		RETEST	
The Candidate:	S	U	S	U
a) Used search techniques that incorporated documentation				
b) Properly examined and removed fire debris				
c) Checked all debris for fire cause evidence				
d) Located and identified the ignition source				
e) Determined the fire cause				
f) Collected and preserved evidence without damage or contamination				
g) Identified and documented explosive effects on glass, walls, foundations, and other building materials				
h) Distinguished and documented between low- and high-order explosion effects				
i) Analyzed damage in order to document the blast zone and origin				
j) Performed skill in a safe and proficient manner				

Reprinted with permission from NFPA 1033, *Professional Qualifications for Fire Investigator*, Copyright ©2022, National Fire Protection Association, Quincy, MA 02169. This reprinted material is not the complete and official position of the National Fire Protection Association on the referenced subject which is represented only by the standard in its entirety.

TEXAS COMMISSION ON FIRE PROTECTION
Fire Investigator
Performance Standards Evaluation

S = Satisfactorily completed/performed

U = Unsatisfactorily performed/failed to meet objective or grading step

All steps of the skill objective are mandatory and must be scored as “Satisfactory” to pass the skill.

Examiner/Candidate Comments:

 Certifying Examiner

 Date

 Re-Test Certifying Examiner

 Date

Overall Skill Test Score			
Pass:		Fail:	
Overall Skill Re-Test Score			
Pass:		Fail:	

Reprinted with permission from NFPA 1033, *Professional Qualifications for Fire Investigator*, Copyright ©2022, National Fire Protection Association, Quincy, MA 02169. This reprinted material is not the complete and official position of the National Fire Protection Association on the referenced subject which is represented only by the standard in its entirety.

TEXAS COMMISSION ON FIRE PROTECTION
Fire Investigator
Performance Standards Evaluation

Skill 7
Reconstructing the Area of Origin

NFPA 1033, 2022 edition
4.2.7

Scene Examination

OBJECTIVE

Reconstruct potential area(s) of origin, given standard and, if needed, special equipment and tools as well as sufficient personnel, so that all protected areas and fire patterns are identified and correlated to contents or structural remains, and items potentially critical to cause determination and photo documentation are returned to their prefire location as a means of hypothesis testing, such that the area(s) or point(s) of origin is discovered. (4.2.7)

INSTRUCTIONS - procedures for achieving the objective

The Investigator candidate shall identify protected areas, locate and replace items moved during fire suppression activities to their pre-fire location, and indicate on a photo log what photos should be taken to document reconstruction.

EXAMINER'S NOTE

The Investigator candidate will not be allowed to review the performance steps at the time of testing.

The fire ground scene may be physically simulated; however, the investigator candidate must perform each step of the required skill in the presence of the field examiner.

PREPARATION & EQUIPMENT

- Fire ground (actual or simulated)
- Standard and special equipment and tools
- Burned items
- Photo log
- Appropriate safety equipment
- Personnel (if needed)

Reprinted with permission from NFPA 1033, *Professional Qualifications for Fire Investigator*, Copyright ©2022, National Fire Protection Association, Quincy, MA 02169. This reprinted material is not the complete and official position of the National Fire Protection Association on the referenced subject which is represented only by the standard in its entirety.

TEXAS COMMISSION ON FIRE PROTECTION
Fire Investigator
Performance Standards Evaluation

Candidate: _____

Training Provider: _____

Test Site: _____

Examiner(s): _____

SKILL 7				
Reconstructing the Area of Origin				
Reconstruct potential area(s) of origin, given standard and, if needed, special equipment and tools as well as sufficient personnel, so that all protected areas and fire patterns are identified and correlated to contents or structural remains; and items potentially critical to cause determination are returned to their prefire location as a means of hypothesis testing, such that the area(s) or point(s) of origin is discovered. (4.2.7)				
	<u>TEST</u>		<u>RETEST</u>	
The Candidate:	S	U	S	U
a) Examined all materials to determine the effects of fire				
b) Identified and distinguished among different types of fire-damaged contents				
c) Returned materials to their original position using protected areas and fire patterns				
d) Performed skill in a safe and proficient manner				

S = Satisfactorily completed/performed

U = Unsatisfactorily performed/failed to meet objective or grading step

All steps of the skill objective are mandatory and must be scored as “Satisfactory” to pass the skill.

Reprinted with permission from NFPA 1033, *Professional Qualifications for Fire Investigator*, Copyright ©2022, National Fire Protection Association, Quincy, MA 02169. This reprinted material is not the complete and official position of the National Fire Protection Association on the referenced subject which is represented only by the standard in its entirety.

TEXAS COMMISSION ON FIRE PROTECTION
Fire Investigator
Performance Standards Evaluation

Examiner/Candidate Comments:

 Certifying Examiner

 Date

 Re-Test Certifying Examiner

 Date

Overall Skill Test Score			
Pass:		Fail:	
Overall Skill Re-Test Score			
Pass:		Fail:	

Reprinted with permission from NFPA 1033, *Professional Qualifications for Fire Investigator*, Copyright ©2022, National Fire Protection Association, Quincy, MA 02169. This reprinted material is not the complete and official position of the National Fire Protection Association on the referenced subject which is represented only by the standard in its entirety.

TEXAS COMMISSION ON FIRE PROTECTION
Fire Investigator
Performance Standards Evaluation

Skill 8

Inspecting the Performance of Building Systems

NFPA 1033, 2022 edition
4.2.8

Scene Examination

OBJECTIVE

Inspect and analyze the performance of building systems, including fire protection, detection and suppression systems, HVAC, electricity and electrical systems, propane and natural gas fuel gas systems, and building compartmentation, given standard and special equipment and tools, so that a determination can be made as to the need for expert resources; an operating system's impact on fire growth and spread is considered in identifying origin areas; defeated and failed systems are identified; and the system's potential as a fire cause is recognized. (4.2.8)

INSTRUCTIONS - procedures for achieving the objective

The Investigator candidate shall inspect and analyze the performance of building systems including fire protection, detection and suppression systems, HVAC, electricity and electrical systems, propane and natural gas fuel gas systems, and building compartmentation, given standard and special equipment and tools, so that a determination can be made as to the need for expert resources; an operating system's impact on fire growth and spread is considered in identifying origin areas; defeated and failed systems are identified; and the system's potential as a fire cause is recognized.

EXAMINER'S NOTE

The Investigator candidate will not be allowed to review the performance steps at the time of testing.

The fire ground scene may be physically simulated; however, the investigator candidate must perform each step of the required skill in the presence of the field examiner.

PREPARATION & EQUIPMENT

- Fire ground (actual and simulated)
- Floor plan
- Building systems
- Appropriate safety equipment
- Standard and special equipment and tools

Reprinted with permission from NFPA 1033, *Professional Qualifications for Fire Investigator*, Copyright ©2022, National Fire Protection Association, Quincy, MA 02169. This reprinted material is not the complete and official position of the National Fire Protection Association on the referenced subject which is represented only by the standard in its entirety.

TEXAS COMMISSION ON FIRE PROTECTION
Fire Investigator
Performance Standards Evaluation

Candidate: _____

Training Provider: _____

Test Site: _____

Examiner(s): _____

SKILL 8				
Inspecting the Performance of Building Systems				
Inspect and analyze the performance of building systems, including fire protection, detection and suppression systems, HVAC, electricity and electrical systems, propane and natural gas fuel gas systems, and building compartmentation, given standard and special equipment and tools, so that a determination can be made as to the need for expert resources; an operating system's impact on fire growth and spread is considered in identifying origin areas; defeated and failed systems are identified; and the system's potential as a fire cause is recognized. (4.2.8)				
The candidate:	<u>TEST</u>		<u>RETEST</u>	
Fire Investigator Safety	S	U	S	U
a) Ensured all utilities are secured and safe				
Fire Protection System:	S	U	S	U
a) Documented type of fire protection system				
b) Documented power supply				
c) Documented functionality of fire protection system				
d) Documented effectiveness of fire protection system				
e) Requested expert resource if needed				
Detection & Suppression System	S	U	S	U
a) Documented type of suppression system				
b) Documented functionality of suppression system				
c) Documented agent supply (water system, tanks, FDC. etc.)				
d) Documented effectiveness of suppression system				
e) Requested expert resource if needed				

Reprinted with permission from NFPA 1033, *Professional Qualifications for Fire Investigator*, Copyright ©2022, National Fire Protection Association, Quincy, MA 02169. This reprinted material is not the complete and official position of the National Fire Protection Association on the referenced subject which is represented only by the standard in its entirety.

TEXAS COMMISSION ON FIRE PROTECTION
Fire Investigator
Performance Standards Evaluation

HVAC System	S	U	S	U
a) Documented type of HVAC system				
b) Documented functionality of HVAC system				
c) Documented effectiveness of HVAC system				
d) Requested expert resource if needed				
Electricity & Electrical System	S	U	S	U
a) Ensured electrical system is safe				
b) Documented supply source(s)				
c) Documented meter base				
d) Documented electrical panel(s)				
e) Requested expert resource if needed				
Fuel Gas System (propane & natural gas)	S	U	S	U
a) Ensured Fuel Gas system is safe				
b) Documented meter				
c) Documented any valves				
d) Requested expert resource if needed				
Building Compartmentation	S	U	S	U
a) Documented any designed compartmentation				
b) Documented any breeches in designed compartmentation				
Fire Growth & Spread, and Cause	S	U	S	U
a) Reported which, if any, and how systems inspected were defective and / or defeated				
b) Recognized and reported system's potential as a fire cause				
c) Reported how systems effected and/or prevented fire growth and spread				

S = Satisfactorily completed/performed

U = Unsatisfactorily performed/failed to meet objective or grading step

All steps of the skill objective are mandatory and must be scored as "Satisfactory" to pass the skill.

Reprinted with permission from NFPA 1033, *Professional Qualifications for Fire Investigator*, Copyright ©2022, National Fire Protection Association, Quincy, MA 02169. This reprinted material is not the complete and official position of the National Fire Protection Association on the referenced subject which is represented only by the standard in its entirety.

TEXAS COMMISSION ON FIRE PROTECTION
Fire Investigator
Performance Standards Evaluation

Examiner/Candidate Comments:

 Certifying Examiner

 Date

 Re-Test Certifying Examiner

 Date

Overall Skill Test Score			
Pass:		Fail:	
Overall Skill Re-Test Score			
Pass:		Fail:	

Reprinted with permission from NFPA 1033, *Professional Qualifications for Fire Investigator*, Copyright ©2022, National Fire Protection Association, Quincy, MA 02169. This reprinted material is not the complete and official position of the National Fire Protection Association on the referenced subject which is represented only by the standard in its entirety.

TEXAS COMMISSION ON FIRE PROTECTION
Fire Investigator
Performance Standards Evaluation

Skill 9
Diagramming the Scene

NFPA 1033, 2022 edition
4.3.1

Documenting the Scene

OBJECTIVE

Diagram the scene, given standard tools and equipment, so that the scene is accurately represented and evidence, pertinent contents, significant patterns, and area(s) or point(s) of origin are identified. (4.3.1)

INSTRUCTIONS - procedures for achieving the objective

The Investigator candidate shall diagram (rough sketch) the fire scene. Diagram shall include at least one item of evidence, one item of pertinent contents, one significant fire pattern, and one area or point of origin.

EXAMINER'S NOTE

The Investigator candidate will not be allowed to review the performance steps at the time of testing.

The fire ground scene may be physically simulated; however, the investigator candidate must perform each step of the required skill in the presence of the field examiner.

PREPARATION & EQUIPMENT

- Safe and secure fire ground (actual or simulated)
- Note pad
- Measuring devices
- An assistant if requested
- Appropriate safety equipment
- Standard equipment and tools

Reprinted with permission from NFPA 1033, *Professional Qualifications for Fire Investigator*, Copyright ©2022, National Fire Protection Association, Quincy, MA 02169. This reprinted material is not the complete and official position of the National Fire Protection Association on the referenced subject which is represented only by the standard in its entirety.

TEXAS COMMISSION ON FIRE PROTECTION
Fire Investigator
Performance Standards Evaluation

Candidate: _____

Training Provider: _____

Test Site: _____

Examiner(s): _____

SKILL 9				
Diagramming the Scene				
Diagram the scene, given standard tools and equipment, so that the scene is accurately represented and evidence, pertinent contents, significant patterns, and area(s) or point(s) of origin are identified. (4.3.1)				
	TEST		RETEST	
The Candidate diagrammed the fire scene to include each of the following:	S	U	S	U
a) Relative locations, dimensions, rooms, stairs, doors and windows				
b) At least one item of evidence with location dimensions indicated				
c) At least one item of pertinent contents with location and dimensions indicated				
d) At least one fire pattern with location identified				
e) Performed skill in a safe and proficient manner				

S = Satisfactorily completed/performed

U = Unsatisfactorily performed/failed to meet objective or grading step

All steps of the skill objective are mandatory and must be scored as “Satisfactory” to pass the skill.

Reprinted with permission from NFPA 1033, *Professional Qualifications for Fire Investigator*, Copyright ©2022, National Fire Protection Association, Quincy, MA 02169. This reprinted material is not the complete and official position of the National Fire Protection Association on the referenced subject which is represented only by the standard in its entirety.

TEXAS COMMISSION ON FIRE PROTECTION
Fire Investigator
Performance Standards Evaluation

Examiner/Candidate Comments:

 Certifying Examiner

 Date

 Re-Test Certifying Examiner

 Date

Overall Skill Test Score			
Pass:		Fail:	
Overall Skill Re-Test Score			
Pass:		Fail:	

Reprinted with permission from NFPA 1033, *Professional Qualifications for Fire Investigator*, Copyright ©2022, National Fire Protection Association, Quincy, MA 02169. This reprinted material is not the complete and official position of the National Fire Protection Association on the referenced subject which is represented only by the standard in its entirety.

TEXAS COMMISSION ON FIRE PROTECTION
Fire Investigator
Performance Standards Evaluation

Skill 10

Photographically Documenting the Scene

NFPA 1033, 2022 edition
4.3.2

Documenting the Scene

OBJECTIVE

Photographically document the scene, given standard tools and equipment, so that the scene is accurately depicted, and the photographs support scene findings. (4.3.2)

INSTRUCTIONS - procedures for achieving the objective

The Investigator candidate shall photograph an interior scene and provide a photo log and photo diagram (rough sketch) of the photo(s) taken.

EXAMINER'S NOTE

The Investigator candidate will not be allowed to review the performance steps at the time of testing.

The fire ground scene may be physically simulated; however, the investigator candidate must perform each step of the required skill in the presence of the field examiner.

PREPARATION & EQUIPMENT

- Fire ground (actual or simulated)
- High-resolution camera, flash, and accessories
- Note pad
- Measuring devices
- Photo log
- Appropriate safety equipment
- Standard equipment and tools

Reprinted with permission from NFPA 1033, *Professional Qualifications for Fire Investigator*, Copyright ©2022, National Fire Protection Association, Quincy, MA 02169. This reprinted material is not the complete and official position of the National Fire Protection Association on the referenced subject which is represented only by the standard in its entirety.

TEXAS COMMISSION ON FIRE PROTECTION
Fire Investigator
Performance Standards Evaluation

Candidate: _____

Training Provider: _____

Test Site: _____

Examiner(s): _____

SKILL 10				
Photographically Documenting the Scene				
Photographically document the scene, given standard tools and equipment, so that the scene is accurately depicted, and the photographs support scene findings. (4.3.2)				
	<u>TEST</u>		<u>RETEST</u>	
The Candidate:	S	U	S	U
a) Photographed exterior survey				
b) Photographed interior survey				
c) Documented photos taken on a photo diagram (rough sketch) and photo log				
d) Performed skill in a safe and proficient manner				

S = Satisfactorily completed/performed

U = Unsatisfactorily performed/failed to meet objective or grading step

All steps of the skill objective are mandatory and must be scored as “Satisfactory” to pass the skill.

Reprinted with permission from NFPA 1033, *Professional Qualifications for Fire Investigator*, Copyright ©2022, National Fire Protection Association, Quincy, MA 02169. This reprinted material is not the complete and official position of the National Fire Protection Association on the referenced subject which is represented only by the standard in its entirety.

TEXAS COMMISSION ON FIRE PROTECTION
Fire Investigator
Performance Standards Evaluation

Examiner/Candidate Comments:

 Certifying Examiner

 Date

 Re-Test Certifying Examiner

 Date

Overall Skill Test Score			
Pass:		Fail:	
Overall Skill Re-Test Score			
Pass:		Fail:	

Reprinted with permission from NFPA 1033, *Professional Qualifications for Fire Investigator*, Copyright ©2022, National Fire Protection Association, Quincy, MA 02169. This reprinted material is not the complete and official position of the National Fire Protection Association on the referenced subject which is represented only by the standard in its entirety.

TEXAS COMMISSION ON FIRE PROTECTION
Fire Investigator
Performance Standards Evaluation

Skill 11
Constructing Investigative Notes

NFPA 1033, 2022 edition
4.3.3

Documenting the Scene

OBJECTIVE

Construct investigative notes, given a fire scene, available documents (e.g. prefire plans and inspection reports), and interview information, so that the notes are accurate, provide further documentation of the scene, and represent complete documentation of the scene findings. (4.3.3)

INSTRUCTIONS - procedures for achieving the objective

The investigator candidate shall take field notes from the scene to be used to compile a final report. The field notes shall include a documented exterior survey, interior survey, area of origin and fire patterns. You will correlate photos and interview information to the fire scene.

EXAMINER'S NOTE

The Investigator candidate will not be allowed to review the performance steps at the time of testing.

The fire ground scene may be physically simulated; however, the investigator candidate must perform each step of the required skill in the presence of the field examiner.

PREPARATION & EQUIPMENT

- Fire scene, actual or simulated
- An investigation file including:
 - Interview information
 - Photos
 - Suppression report
 - Any available pre-fire information

Reprinted with permission from NFPA 1033, *Professional Qualifications for Fire Investigator*, Copyright ©2022, National Fire Protection Association, Quincy, MA 02169. This reprinted material is not the complete and official position of the National Fire Protection Association on the referenced subject which is represented only by the standard in its entirety.

TEXAS COMMISSION ON FIRE PROTECTION
Fire Investigator
Performance Standards Evaluation

Candidate: _____

Training Provider: _____

Test Site: _____

Examiner(s): _____

SKILL 11				
Constructing Investigative Notes				
Construct investigative notes, given a fire scene, available documents (e.g. prefire plans and inspection reports), and interview information, so that the notes are accurate, provide further documentation of the scene, and represent complete documentation of the scene findings. (4.3.3)				
	<u>TEST</u>		<u>RETEST</u>	
The Candidate:	S	U	S	U
a) Reduced scene observations to reliable and accurate notes				
b) Documented exterior survey, interior survey, area of origin, fire effects, and fire patterns				
c) Documented photos taken on a photo rough sketch and photo log				
d) Correlated photos and interview information to fire scene observations				
e) Performed skill in a safe and proficient manner				

S = Satisfactorily completed/performed

U = Unsatisfactorily performed/failed to meet objective or grading step

All steps of the skill objective are mandatory and must be scored as “Satisfactory” to pass the skill.

Reprinted with permission from NFPA 1033, *Professional Qualifications for Fire Investigator*, Copyright ©2022, National Fire Protection Association, Quincy, MA 02169. This reprinted material is not the complete and official position of the National Fire Protection Association on the referenced subject which is represented only by the standard in its entirety.

TEXAS COMMISSION ON FIRE PROTECTION
Fire Investigator
Performance Standards Evaluation

Examiner/Candidate Comments:

 Certifying Examiner

 Date

 Re-Test Certifying Examiner

 Date

Overall Skill Test Score			
Pass:		Fail:	
Overall Skill Re-Test Score			
Pass:		Fail:	

Reprinted with permission from NFPA 1033, *Professional Qualifications for Fire Investigator*, Copyright ©2022, National Fire Protection Association, Quincy, MA 02169. This reprinted material is not the complete and official position of the National Fire Protection Association on the referenced subject which is represented only by the standard in its entirety.

TEXAS COMMISSION ON FIRE PROTECTION
Fire Investigator
Performance Standards Evaluation

Skill 12

Utilizing Proper Procedures for Managing Victims and Fatalities

NFPA 1033, 2022 edition
4.4.1, 4.4.2, 4.4.3

Evidence Collection/Preservation

OBJECTIVE

Utilize proper procedures for managing victims and fatalities, given protocol and appropriate personnel, so that all evidence is discovered and preserved and the protocol procedures are followed. (4.4.1)

Locate, document, collect, label, package and store evidence, given standard or special tools and equipment and evidence collection materials, so that it is properly identified, preserved, collected, packaged and stored for use in testing, legal, or other proceedings and examinations, ensuring cross-contamination and investigator-inflicted damage to evidentiary items is avoided and the chain of custody is established. (4.4.2)

Select evidence for analysis given all information from the investigation, so that items for analysis support specific investigation needs. (4.4.3)

INSTRUCTIONS - procedures for achieving the objective

The Investigator candidate shall follow procedures to manage a victim OR fatality and to discover and preserve ALL evidence. The Investigator candidate shall then collect and package two different types of identified evidence, fill out a standard crime lab analysis request form indicating specific test(s) requested, while maintaining chain of custody and avoiding contamination.

EXAMINER'S NOTE

The Investigator candidate will not be allowed to review the performance steps at the time of testing.

The fire ground scene may be physically simulated; however, the investigator candidate must perform each step of the required skill in the presence of the field examiner.

TEXAS COMMISSION ON FIRE PROTECTION
Fire Investigator
Performance Standards Evaluation

PREPARATION & EQUIPMENT

- Fire ground (actual or simulated)
- Several types of evidence
- A standard crime lab analysis request form
- Needed evidence collection supplies
- Note pad
- Camera
- Simulated victim or fatality
- Appropriate safety equipment
- Standard equipment and tools

Reprinted with permission from NFPA 1033, *Professional Qualifications for Fire Investigator*, Copyright ©2022, National Fire Protection Association, Quincy, MA 02169. This reprinted material is not the complete and official position of the National Fire Protection Association on the referenced subject which is represented only by the standard in its entirety.

TEXAS COMMISSION ON FIRE PROTECTION
Fire Investigator
Performance Standards Evaluation

Candidate: _____

Training Provider: _____

Test Site: _____

Examiner(s): _____

SKILL 12				
Utilizing Proper Procedures for Managing Victims and Fatalities				
Utilize proper procedures for managing victims and fatalities, given a protocol and appropriate personnel, so that all evidence is discovered and preserved and the protocol procedures are followed. (4.4.1)				
Locate, document, collect, label, package and store evidence, given standard or special tools and equipment and evidence collection materials, so that it is properly identified, preserved, collected, packaged and stored for use in testing, legal, or other proceedings and examinations, ensuring cross- contamination and investigator-inflicted damage to evidentiary items is avoided and the chain of custody is established. (4.4.2)				
Select evidence for analysis given all information from the investigation, so that items for analysis support specific investigation needs. (4.4.3)				
	<u>TEST</u>		<u>RETEST</u>	
The Candidate:	S	U	S	U
a) Utilized proper procedures to manage a victim or fatality				
b) Properly discovered and preserved all evidence				
c) Identified two different types of evidence				
d) Selected, documented and collected one of each of the two types of evidence				
e) Packaged, labeled and stored selected/collected items				
f) Ensured cross-contamination and investigator- inflicted damage to evidentiary items is avoided				
g) Properly completed the crime lab analysis request form indicating the specific analysis requested				

Reprinted with permission from NFPA 1033, *Professional Qualifications for Fire Investigator*, Copyright ©2022, National Fire Protection Association, Quincy, MA 02169. This reprinted material is not the complete and official position of the National Fire Protection Association on the referenced subject which is represented only by the standard in its entirety.

TEXAS COMMISSION ON FIRE PROTECTION
Fire Investigator
Performance Standards Evaluation

h) Documented the process in field notes and photography				
i) Performed skill in a safe and proficient manner				

S = Satisfactorily completed/performed

U = Unsatisfactorily performed/failed to meet objective or grading step

All steps of the skill objective are mandatory and must be scored as “Satisfactory” to pass the skill.

Examiner/Candidate Comments:

 Certifying Examiner

 Date

Overall Skill Test Score			
Pass:		Fail:	
Overall Skill Re-Test Score			
Pass:		Fail:	

 Re-Test Certifying Examiner

 Date

Reprinted with permission from NFPA 1033, *Professional Qualifications for Fire Investigator*, Copyright ©2022, National Fire Protection Association, Quincy, MA 02169. This reprinted material is not the complete and official position of the National Fire Protection Association on the referenced subject which is represented only by the standard in its entirety.

TEXAS COMMISSION ON FIRE PROTECTION
Fire Investigator
Performance Standards Evaluation

Skill 13
Maintaining a Chain of Custody

NFPA 1033, 2022 edition
4.4.4

Evidence Collection/Preservation

OBJECTIVE

Maintain a chain of custody, given standard investigative tools; marking tools, and evidence tags or logs, so that written documentation exists for each piece of evidence and evidence is secured. (4.4.4)

INSTRUCTIONS - procedures for achieving the objective

The Investigator candidate shall mark, package, transfer custody and log two items of evidence.

EXAMINER'S NOTE

The Investigator candidate will not be allowed to review the performance steps at the time of testing.

PREPARATION & EQUIPMENT

- Forms
- Tags
- Two items of evidence
- Appropriate safety equipment
- Standard equipment and tools

Reprinted with permission from NFPA 1033, *Professional Qualifications for Fire Investigator*, Copyright ©2022, National Fire Protection Association, Quincy, MA 02169. This reprinted material is not the complete and official position of the National Fire Protection Association on the referenced subject which is represented only by the standard in its entirety.

TEXAS COMMISSION ON FIRE PROTECTION
Fire Investigator
Performance Standards Evaluation

Candidate: _____

Training Provider: _____

Test Site: _____

Examiner(s): _____

SKILL 13				
Maintaining a Chain of Custody				
Maintain a chain of custody, given standard investigative tools, marking tools, and evidence tags or logs, so that written documentation exists for each piece of evidence and evidence is secured. (4.4.4)				
	<u>TEST</u>		<u>RETEST</u>	
The Candidate:	S	U	S	U
a) Marked and/or tagged and packaged two pieces of evidence				
b) Maintained chain of custody by correctly utilizing logs and/or forms during the transfer of evidence				
c) Performed skill in a safe and proficient manner				

S = Satisfactorily completed/performed

U = Unsatisfactorily performed/failed to meet objective or grading step

All steps of the skill objective are mandatory and must be scored as “Satisfactory” to pass the skill.

Reprinted with permission from NFPA 1033, *Professional Qualifications for Fire Investigator*, Copyright ©2022, National Fire Protection Association, Quincy, MA 02169. This reprinted material is not the complete and official position of the National Fire Protection Association on the referenced subject which is represented only by the standard in its entirety.

TEXAS COMMISSION ON FIRE PROTECTION
Fire Investigator
Performance Standards Evaluation

Examiner/Candidate Comments:

 Certifying Examiner

 Date

Overall Skill Test Score			
Pass:		Fail:	
Overall Skill Re-Test Score			
Pass:		Fail:	

 Re-Test Certifying Examiner

 Date

Reprinted with permission from NFPA 1033, *Professional Qualifications for Fire Investigator*, Copyright ©2022, National Fire Protection Association, Quincy, MA 02169. This reprinted material is not the complete and official position of the National Fire Protection Association on the referenced subject which is represented only by the standard in its entirety.

TEXAS COMMISSION ON FIRE PROTECTION
Fire Investigator
Performance Standards Evaluation

Skill 14
Disposing of Evidence

NFPA 1033, 2022 edition
4.4.5

Evidence Collection/Preservation

OBJECTIVE

Dispose of evidence, given jurisdictional or agency regulations and file information, so that the disposal is timely, safely conducted, and in compliance with jurisdictional or agency requirements. (4.4.5)

INSTRUCTIONS - procedures for achieving the objective

The Investigator candidate shall dispose of evidence in a timely and safe manner and document the disposal of evidence.

EXAMINER'S NOTE

The Investigator candidate will not be allowed to review the performance steps at the time of testing.

PREPARATION & EQUIPMENT

- Incident information
- Model evidence policy
- Evidence
- Evidence disposal forms

Reprinted with permission from NFPA 1033, *Professional Qualifications for Fire Investigator*, Copyright ©2022, National Fire Protection Association, Quincy, MA 02169. This reprinted material is not the complete and official position of the National Fire Protection Association on the referenced subject which is represented only by the standard in its entirety.

TEXAS COMMISSION ON FIRE PROTECTION
Fire Investigator
Performance Standards Evaluation

Candidate: _____

Training Provider: _____

Test Site: _____

Examiner(s): _____

SKILL 14				
Disposing of Evidence				
Dispose of evidence, given jurisdictional or agency regulations and file information, so that the disposal is timely, safely conducted, and in compliance with jurisdictional or agency requirements. (4.4.5)				
	TEST		RETEST	
The Candidate:	S	U	S	U
a) Identified evidence subject to disposal				
b) Disposed of evidence according to the model evidence policy				
c) Documented disposal of the evidence using the provided forms				
d) Performed skill in a safe and proficient manner				

S = Satisfactorily completed/performed

U = Unsatisfactorily performed/failed to meet objective or grading step

All steps of the skill objective are mandatory and must be scored as “Satisfactory” to pass the skill.

Reprinted with permission from NFPA 1033, *Professional Qualifications for Fire Investigator*, Copyright ©2022, National Fire Protection Association, Quincy, MA 02169. This reprinted material is not the complete and official position of the National Fire Protection Association on the referenced subject which is represented only by the standard in its entirety.

TEXAS COMMISSION ON FIRE PROTECTION
Fire Investigator
Performance Standards Evaluation

Examiner/Candidate Comments:

 Certifying Examiner

 Date

 Re-Test Certifying Examiner

 Date

Overall Skill Test Score			
Pass:		Fail:	
Overall Skill Re-Test Score			
Pass:		Fail:	

Reprinted with permission from NFPA 1033, *Professional Qualifications for Fire Investigator*, Copyright ©2022, National Fire Protection Association, Quincy, MA 02169. This reprinted material is not the complete and official position of the National Fire Protection Association on the referenced subject which is represented only by the standard in its entirety.

TEXAS COMMISSION ON FIRE PROTECTION
Fire Investigator
Performance Standards Evaluation

Skill 15
Developing an Interview Plan

NFPA 1033, 2022 edition
4.5.1

Interview

OBJECTIVE

Develop an interview plan, given no special tools or equipment, so that the plan reflects a strategy to further determine the fire cause and affix responsibility and includes a relevant questioning strategy for each individual to be interviewed that promotes the efficient use of the investigator's time. (4.5.1)

INSTRUCTIONS - procedures for achieving the objective

The Investigator candidate shall develop an interview plan that assists in fire cause and suspect determination.

EXAMINER'S NOTE

The Investigator candidate will not be allowed to review the performance steps at the time of testing.

PREPARATION & EQUIPMENT

- Incident information
- Witness statement
- Notepad

Reprinted with permission from NFPA 1033, *Professional Qualifications for Fire Investigator*, Copyright ©2022, National Fire Protection Association, Quincy, MA 02169. This reprinted material is not the complete and official position of the National Fire Protection Association on the referenced subject which is represented only by the standard in its entirety.

TEXAS COMMISSION ON FIRE PROTECTION
Fire Investigator
Performance Standards Evaluation

Candidate: _____

Training Provider: _____

Test Site: _____

Examiner(s): _____

SKILL 15				
Developing an Interview Plan				
Develop an interview plan, given no special tools or equipment, so that the plan reflects a strategy to further determine the fire cause and affix responsibility and includes a relevant questioning strategy for each individual to be interviewed that promotes the efficient use of the investigator's time. (4.5.1)				
	<u>TEST</u>		<u>RETEST</u>	
The Candidate:	S	U	S	U
a) Reviewed provided information and requested additional information if needed				
b) Developed an interview plan strategy for a person of interest				
c) Documented the interview strategy by listing relevant questions				
d) Verbally identified the pros and cons of doing interviews versus document gathering				
e) Performed skill in a safe and proficient manner				

S = Satisfactorily completed/performed

U = Unsatisfactorily performed/failed to meet objective or grading step

All steps of the skill objective are mandatory and must be scored as "Satisfactory" to pass the skill.

Reprinted with permission from NFPA 1033, *Professional Qualifications for Fire Investigator*, Copyright ©2022, National Fire Protection Association, Quincy, MA 02169. This reprinted material is not the complete and official position of the National Fire Protection Association on the referenced subject which is represented only by the standard in its entirety.

TEXAS COMMISSION ON FIRE PROTECTION
Fire Investigator
Performance Standards Evaluation

Examiner/Candidate Comments:

 Certifying Examiner

 Date

 Re-Test Certifying Examiner

 Date

Overall Skill Test Score			
Pass:		Fail:	
Overall Skill Re-Test Score			
Pass:		Fail:	

Reprinted with permission from NFPA 1033, *Professional Qualifications for Fire Investigator*, Copyright ©2022, National Fire Protection Association, Quincy, MA 02169. This reprinted material is not the complete and official position of the National Fire Protection Association on the referenced subject which is represented only by the standard in its entirety.

TEXAS COMMISSION ON FIRE PROTECTION
Fire Investigator
Performance Standards Evaluation

Skill 16
Conducting Interviews

NFPA 1033, 2022 edition
4.5.2

Interview

OBJECTIVE

Conduct interviews, given incident information, so that pertinent information is obtained, follow-up questions are asked, responses to all questions are elicited, and the response to each question is documented accurately. (4.5.2)

INSTRUCTIONS - procedures for achieving the objective

The Investigator candidate shall conduct a witness interview. During the interview, the witness shall become a suspect. The Investigator candidate shall change questioning techniques and conduct an interrogation.

EXAMINER'S NOTE

The Investigator candidate will not be allowed to review the performance steps at the time of testing.

PREPARATION & EQUIPMENT

- Interview room setting
- Incident information
- Witness statement
- Forms
- Note pad

Reprinted with permission from NFPA 1033, *Professional Qualifications for Fire Investigator*, Copyright ©2022, National Fire Protection Association, Quincy, MA 02169. This reprinted material is not the complete and official position of the National Fire Protection Association on the referenced subject which is represented only by the standard in its entirety.

TEXAS COMMISSION ON FIRE PROTECTION
Fire Investigator
Performance Standards Evaluation

Candidate: _____

Training Provider: _____

Test Site: _____

Examiner(s): _____

SKILL 16				
Conducting Interviews				
Conduct interviews, given incident information, so that pertinent information is obtained, follow-up questions are asked, responses to all questions are elicited, and the response to each question is documented accurately. (4.5.2)				
	TEST		RETEST	
The Candidate:	S	U	S	U
a) Obtained incident briefing and took notes				
b) Identified the witness				
c) Conducted and documented the interview				
d) Recognized when witness became a suspect				
e) Applied legal requirements applicable				
f) Conducted and documented the interrogation				
g) Interpreted verbal and nonverbal communications				
h) Exhibited strong listening skills				
i) Performed skill in a safe and proficient manner				

S = Satisfactorily completed/performed

U = Unsatisfactorily performed/failed to meet objective or grading step

All steps of the skill objective are mandatory and must be scored as “Satisfactory” to pass the skill.

Reprinted with permission from NFPA 1033, *Professional Qualifications for Fire Investigator*, Copyright ©2022, National Fire Protection Association, Quincy, MA 02169. This reprinted material is not the complete and official position of the National Fire Protection Association on the referenced subject which is represented only by the standard in its entirety.

TEXAS COMMISSION ON FIRE PROTECTION
Fire Investigator
Performance Standards Evaluation

Examiner/Candidate Comments:

 Certifying Examiner

 Date

 Re-Test Certifying Examiner

 Date

Overall Skill Test Score			
Pass:		Fail:	
Overall Skill Re-Test Score			
Pass:		Fail:	

Reprinted with permission from NFPA 1033, *Professional Qualifications for Fire Investigator*, Copyright ©2022, National Fire Protection Association, Quincy, MA 02169. This reprinted material is not the complete and official position of the National Fire Protection Association on the referenced subject which is represented only by the standard in its entirety.

TEXAS COMMISSION ON FIRE PROTECTION
Fire Investigator
Performance Standards Evaluation

Skill 17
Evaluating Interview Information

NFPA 1033, 2022 edition
4.5.3

Interview

OBJECTIVE

Evaluate interview information, given interview transcripts or notes and incident data, so that all interview data is individually analyzed and correlated with all other interviews, corroborative and conflictive information is documented, and new leads are developed. (4.5.3)

INSTRUCTIONS - procedures for achieving the objective

The Investigator candidate shall evaluate, analyze, and correlate interview information to determine if the information is corroborative or conflictive in nature, and develop new investigative leads.

EXAMINER'S NOTE

The Investigator candidate will not be allowed to review the performance steps at the time of testing.

PREPARATION & EQUIPMENT

- Incident information
- Interview transcripts
- Note pad

Reprinted with permission from NFPA 1033, *Professional Qualifications for Fire Investigator*, Copyright ©2022, National Fire Protection Association, Quincy, MA 02169. This reprinted material is not the complete and official position of the National Fire Protection Association on the referenced subject which is represented only by the standard in its entirety.

TEXAS COMMISSION ON FIRE PROTECTION
Fire Investigator
Performance Standards Evaluation

Candidate: _____

Training Provider: _____

Test Site: _____

Examiner(s): _____

SKILL 17				
Evaluating Interview Information				
Evaluate interview information, given interview transcripts or notes and incident data, so that all interview data is individually analyzed and correlated with all other interviews, corroborative and conflictive information is documented, and new leads are developed. (4.5.3)				
	TEST		RETEST	
The Candidate:	S	U	S	U
a) Reviewed provided information				
b) Correlated information into corroborative or conflicting groups				
c) Documented new investigative leads				
d) Performed skill in a safe and proficient manner				

S = Satisfactorily completed/performed

U = Unsatisfactorily performed/failed to meet objective or grading step

All steps of the skill objective are mandatory and must be scored as “Satisfactory” to pass the skill.

Reprinted with permission from NFPA 1033, *Professional Qualifications for Fire Investigator*, Copyright ©2022, National Fire Protection Association, Quincy, MA 02169. This reprinted material is not the complete and official position of the National Fire Protection Association on the referenced subject which is represented only by the standard in its entirety.

TEXAS COMMISSION ON FIRE PROTECTION
Fire Investigator
Performance Standards Evaluation

Examiner/Candidate Comments:

 Certifying Examiner

 Date

 Re-Test Certifying Examiner

 Date

Overall Skill Test Score			
Pass:		Fail:	
Overall Skill Re-Test Score			
Pass:		Fail:	

Reprinted with permission from NFPA 1033, *Professional Qualifications for Fire Investigator*, Copyright ©2022, National Fire Protection Association, Quincy, MA 02169. This reprinted material is not the complete and official position of the National Fire Protection Association on the referenced subject which is represented only by the standard in its entirety.

TEXAS COMMISSION ON FIRE PROTECTION
Fire Investigator
Performance Standards Evaluation

Skill 18
Gathering Reports and Records

NFPA 1033, 2022 edition
4.6.1

Post-Incident Investigation

OBJECTIVE

Gather reports and records, given no special tools, equipment, or materials, so that all gathered documents are applicable to the investigation, complete, and authentic; the chain of custody is maintained; and the material is admissible in a legal proceeding. (4.6.1)

INSTRUCTIONS - procedures for achieving the objective

The Investigator candidate shall gather reports/records given no special tools, equipment, or materials, so that all gathered documents are appropriate to the investigation, complete and authentic, and the chain of custody is maintained.

EXAMINER'S NOTE

The Investigator candidate will not be allowed to review the performance steps at the time of testing.

PREPARATION & EQUIPMENT

- Several different sources of reports and records

TEXAS COMMISSION ON FIRE PROTECTION
Fire Investigator
Performance Standards Evaluation

Candidate: _____

Training Provider: _____

Test Site: _____

Examiner(s): _____

SKILL 18				
Gathering Reports and Records				
Gather reports and records, given no special tools, equipment, or materials, so that all gathered documents are applicable to the investigation, complete, and authentic; the chain of custody is maintained; and the material is admissible in a legal proceeding. (4.6.1)				
	<u>TEST</u>		<u>RETEST</u>	
The Candidate:	S	U	S	U
a) Reviewed provided materials				
b) Identified additional needed materials				
c) Verbally explained how you would obtain the requested materials				
d) Verbally explained how you would maintain chain of custody of requested documents				
e) Performed skill in a safe and proficient manner				

S = Satisfactorily completed/performed

U = Unsatisfactorily performed/failed to meet objective or grading step

All steps of the skill objective are mandatory and must be scored as “Satisfactory” to pass the skill.

Reprinted with permission from NFPA 1033, *Professional Qualifications for Fire Investigator*, Copyright ©2022, National Fire Protection Association, Quincy, MA 02169. This reprinted material is not the complete and official position of the National Fire Protection Association on the referenced subject which is represented only by the standard in its entirety.

TEXAS COMMISSION ON FIRE PROTECTION
Fire Investigator
Performance Standards Evaluation

Examiner/Candidate Comments:

 Certifying Examiner

 Date

 Re-Test Certifying Examiner

 Date

Overall Skill Test Score			
Pass:		Fail:	
Overall Skill Re-Test Score			
Pass:		Fail:	

Reprinted with permission from NFPA 1033, *Professional Qualifications for Fire Investigator*, Copyright ©2022, National Fire Protection Association, Quincy, MA 02169. This reprinted material is not the complete and official position of the National Fire Protection Association on the referenced subject which is represented only by the standard in its entirety.

TEXAS COMMISSION ON FIRE PROTECTION
Fire Investigator
Performance Standards Evaluation

Skill 19
Evaluating the Investigative File

NFPA 1033, 2022 edition
4.6.2

Post-Incident Investigation

OBJECTIVE

Evaluate the investigative file, given all available file information, so that areas for further investigation are identified, the relationship between gathered documents and information is interpreted, and corroborative evidence and information discrepancies are discovered. (4.6.2)

INSTRUCTIONS - procedures for achieving the objective

The Investigator candidate shall evaluate an investigative file, given all available file information, so that areas for further investigation are identified. Information shall be assessed, correlated and organized.

EXAMINER'S NOTE

The Investigator candidate will not be allowed to review the performance steps at the time of testing.

PREPARATION & EQUIPMENT

- Investigative file

Reprinted with permission from NFPA 1033, *Professional Qualifications for Fire Investigator*, Copyright ©2022, National Fire Protection Association, Quincy, MA 02169. This reprinted material is not the complete and official position of the National Fire Protection Association on the referenced subject which is represented only by the standard in its entirety.

TEXAS COMMISSION ON FIRE PROTECTION
Fire Investigator
Performance Standards Evaluation

Candidate: _____

Training Provider: _____

Test Site: _____

Examiner(s): _____

SKILL 19				
Evaluating the Investigative File				
Evaluate the investigative file, given all available file information, so that areas for further investigation are identified, the relationship between gathered documents and information is interpreted, and corroborative evidence and information discrepancies are discovered. (4.6.2)				
	<u>TEST</u>		<u>RETEST</u>	
The Candidate:	S	U	S	U
a) Assessed information				
b) Correlated information				
c) Organized information				
d) Performed skill in a safe and proficient manner				

S = Satisfactorily completed/performed

U = Unsatisfactorily performed/failed to meet objective or grading step

All steps of the skill objective are mandatory and must be scored as “Satisfactory” to pass the skill.

Reprinted with permission from NFPA 1033, *Professional Qualifications for Fire Investigator*, Copyright ©2022, National Fire Protection Association, Quincy, MA 02169. This reprinted material is not the complete and official position of the National Fire Protection Association on the referenced subject which is represented only by the standard in its entirety.

TEXAS COMMISSION ON FIRE PROTECTION
Fire Investigator
Performance Standards Evaluation

Examiner/Candidate Comments:

 Certifying Examiner

 Date

 Re-Test Certifying Examiner

 Date

Overall Skill Test Score			
Pass:		Fail:	
Overall Skill Re-Test Score			
Pass:		Fail:	

Reprinted with permission from NFPA 1033, *Professional Qualifications for Fire Investigator*, Copyright ©2022, National Fire Protection Association, Quincy, MA 02169. This reprinted material is not the complete and official position of the National Fire Protection Association on the referenced subject which is represented only by the standard in its entirety.

TEXAS COMMISSION ON FIRE PROTECTION
Fire Investigator
Performance Standards Evaluation

Skill 20
Coordinating Expert Resources

NFPA 1033, 2022 edition
4.6.3

Post-Incident Investigation

OBJECTIVE

Coordinate expert resources, given the investigative file, reports, and documents, so that the expert's competencies are matched to the specific investigation needs, financial expenditures are justified, and utilization clearly furthers the investigative goals of determining cause or affixing responsibility. (4.6.3)

INSTRUCTIONS - procedures for achieving the objective

The Investigator candidate shall coordinate expert resources, given the investigative file, reports, and documents so that the expert's competencies are matched to the specific investigation needs, financial expenditures are justified, and demonstrate that use of the expert clearly furthers the investigation's goals.

EXAMINER'S NOTE

The Investigator candidate will not be allowed to review the performance steps at the time of testing.

PREPARATION & EQUIPMENT

- Investigative file
- Reports and documents

Reprinted with permission from NFPA 1033, *Professional Qualifications for Fire Investigator*, Copyright ©2022, National Fire Protection Association, Quincy, MA 02169. This reprinted material is not the complete and official position of the National Fire Protection Association on the referenced subject which is represented only by the standard in its entirety.

TEXAS COMMISSION ON FIRE PROTECTION
Fire Investigator
Performance Standards Evaluation

Candidate: _____

Training Provider: _____

Test Site: _____

Examiner(s): _____

SKILL 20				
Coordinating Expert Resources				
Coordinate expert resources, given the investigative file, reports, and documents, so that the expert's competencies are matched to the specific investigation needs, financial expenditures are justified, and utilization clearly furthers the investigative goals of determining cause or affixing responsibility. (4.6.3)				
	TEST		RETEST	
The Candidate:	S	U	S	U
a) Verbally identified the need for specific experts				
b) Verbally identified resources for networking to identify experts				
c) Developed questions to determine the qualifications of experts				
d) Verbally justified costs for an expert witness				
e) Documented how the selected expert witnesses will be utilized to assist in the determination of causation or affixing responsibility				
f) Performed skill in a safe and proficient manner				

S = Satisfactorily completed/performed

U = Unsatisfactorily performed/failed to meet objective or grading step

All steps of the skill objective are mandatory and must be scored as "Satisfactory" to pass the skill.

Reprinted with permission from NFPA 1033, *Professional Qualifications for Fire Investigator*, Copyright ©2022, National Fire Protection Association, Quincy, MA 02169. This reprinted material is not the complete and official position of the National Fire Protection Association on the referenced subject which is represented only by the standard in its entirety.

TEXAS COMMISSION ON FIRE PROTECTION
Fire Investigator
Performance Standards Evaluation

Examiner/Candidate Comments:

 Certifying Examiner

 Date

 Re-Test Certifying Examiner

 Date

Overall Skill Test Score			
Pass:		Fail:	
Overall Skill Re-Test Score			
Pass:		Fail:	

Reprinted with permission from NFPA 1033, *Professional Qualifications for Fire Investigator*, Copyright ©2022, National Fire Protection Association, Quincy, MA 02169. This reprinted material is not the complete and official position of the National Fire Protection Association on the referenced subject which is represented only by the standard in its entirety.

TEXAS COMMISSION ON FIRE PROTECTION
Fire Investigator
Performance Standards Evaluation

Skill 21

Establishing Evidence as to Motive and/or Opportunity – Incendiary Fire

NFPA 1033, 2022 edition
4.6.4

Post-Incident Investigation

OBJECTIVE

Establish evidence as to motive and/or opportunity, given an incendiary fire, so that the evidence is supported by documentation and meets the evidentiary requirements of the jurisdiction. (4.6.4)

INSTRUCTIONS - procedures for achieving the objective

The Investigator candidate shall establish evidence as to motive and/or opportunity so that the evidence is supported by documentation and meets the evidentiary requirements of the AHJ. Investigator candidates shall verbalize all potential hypotheses and select a final hypothesis.

EXAMINER'S NOTE

The Investigator candidate will not be allowed to review the performance steps at the time of testing.

The fire ground scene may be physically simulated; however, the investigator candidate must perform each step of the required skill in the presence of the field examiner.

PREPARATION & EQUIPMENT

- A complete incendiary fire investigation file
- Evidence log
- Financial records

Reprinted with permission from NFPA 1033, *Professional Qualifications for Fire Investigator*, Copyright ©2022, National Fire Protection Association, Quincy, MA 02169. This reprinted material is not the complete and official position of the National Fire Protection Association on the referenced subject which is represented only by the standard in its entirety.

TEXAS COMMISSION ON FIRE PROTECTION
Fire Investigator
Performance Standards Evaluation

Candidate: _____

Training Provider: _____

Test Site: _____

Examiner(s): _____

SKILL 21				
Establishing Evidence as to Motive and/or Opportunity – Incendiary Fire				
Establish evidence as to motive and/or opportunity so that the evidence is supported by documentation and meets the evidentiary requirements of the AHJ. (4.6.4)				
	<u>TEST</u>		<u>RETEST</u>	
The Candidate:	S	U	S	U
a) Reviewed provided materials				
b) Determined and verbalizes the motive and/or opportunity of the incendiary fire				
c) Listed supporting documents that establish motive findings				
d) Verbalized evidence used to determine motive				
e) Verbalized legal value of evidence provided				
f) Verbalized three or more hypotheses				
g) Verbalized final hypothesis				

S = Satisfactorily completed/performed

U = Unsatisfactorily performed/failed to meet objective or grading step

All steps of the skill objective are mandatory and must be scored as “Satisfactory” to pass the skill.

Reprinted with permission from NFPA 1033, *Professional Qualifications for Fire Investigator*, Copyright ©2022, National Fire Protection Association, Quincy, MA 02169. This reprinted material is not the complete and official position of the National Fire Protection Association on the referenced subject which is represented only by the standard in its entirety.

TEXAS COMMISSION ON FIRE PROTECTION
Fire Investigator
Performance Standards Evaluation

Examiner/Candidate Comments:

 Certifying Examiner

 Date

 Re-Test Certifying Examiner

 Date

Overall Skill Test Score			
Pass:		Fail:	
Overall Skill Re-Test Score			
Pass:		Fail:	

Reprinted with permission from NFPA 1033, *Professional Qualifications for Fire Investigator*, Copyright ©2022, National Fire Protection Association, Quincy, MA 02169. This reprinted material is not the complete and official position of the National Fire Protection Association on the referenced subject which is represented only by the standard in its entirety.

TEXAS COMMISSION ON FIRE PROTECTION
Fire Investigator
Performance Standards Evaluation

Skill 22

Formulating an Opinion of the Person(s) and/or Product(s) Responsible for the Fire

NFPA 1033, 2022 edition
4.6.5

Post-Incident Investigation

OBJECTIVE

Formulate an opinion concerning origin, cause, or responsibility for the fire, given all investigative findings, so that the opinion regarding origin, cause, or responsibility for a fire is supported by the data, facts, records, reports, documents, and evidence. (4.6.5)

INSTRUCTIONS - procedures for achieving the objective

The Investigator candidate shall formulate an opinion of the person(s) and/or product(s) responsible for the fire.

EXAMINER'S NOTE

The Investigator candidate will not be allowed to review the performance steps at the time of testing.

PREPARATION & EQUIPMENT

- A complete fire investigation file including:
 - Records
 - Documents
 - Evidence

Reprinted with permission from NFPA 1033, *Professional Qualifications for Fire Investigator*, Copyright ©2022, National Fire Protection Association, Quincy, MA 02169. This reprinted material is not the complete and official position of the National Fire Protection Association on the referenced subject which is represented only by the standard in its entirety.

TEXAS COMMISSION ON FIRE PROTECTION
Fire Investigator
Performance Standards Evaluation

Candidate: _____

Training Provider: _____

Test Site: _____

Examiner(s): _____

SKILL 22				
Formulating an Opinion of the Person(s) and/or Product(s) Responsible for the Fire				
Formulate an opinion concerning origin, cause, or responsibility for the fire, given all investigative findings, so that the opinion regarding origin, cause, or responsibility for a fire is supported by the data, facts, records, reports, documents, and evidence. (4.6.5)				
	<u>TEST</u>		<u>RETEST</u>	
The Candidate:	S	U	S	U
a) Formulated, supported and documented an opinion as to the person and/or product responsible for the fire				
b) Formed an opinion regarding origin, cause, or responsibility for a fire which is supported by the data, facts, records, reports, documents, and evidence				
c) Performed skill in a safe and proficient manner				

S = Satisfactorily completed/performed

U = Unsatisfactorily performed/failed to meet objective or grading step

All steps of the skill objective are mandatory and must be scored as "Satisfactory" to pass the skill.

Reprinted with permission from NFPA 1033, *Professional Qualifications for Fire Investigator*, Copyright ©2022, National Fire Protection Association, Quincy, MA 02169. This reprinted material is not the complete and official position of the National Fire Protection Association on the referenced subject which is represented only by the standard in its entirety.

TEXAS COMMISSION ON FIRE PROTECTION
Fire Investigator
Performance Standards Evaluation

Examiner/Candidate Comments:

 Certifying Examiner

 Date

 Re-Test Certifying Examiner

 Date

Overall Skill Test Score			
Pass:		Fail:	
Overall Skill Re-Test Score			
Pass:		Fail:	

Reprinted with permission from NFPA 1033, *Professional Qualifications for Fire Investigator*, Copyright ©2022, National Fire Protection Association, Quincy, MA 02169. This reprinted material is not the complete and official position of the National Fire Protection Association on the referenced subject which is represented only by the standard in its entirety.

TEXAS COMMISSION ON FIRE PROTECTION
Fire Investigator
Performance Standards Evaluation

Skill 23
Preparing a Written Investigation Report

NFPA 1033, 2022 edition
4.7.1

Presentations

OBJECTIVE

Prepare a written report, given investigative findings, documentation, and a specific audience, so that the report accurately reflects the investigative findings, is concise, expresses the investigator's opinion, contains facts and data that the investigator relies on in rendering an opinion, contains the reasoning of the investigator by which each opinion was reached, and meets the needs or requirements of the intended audience(s). (4.7.1)

INSTRUCTIONS - procedures for achieving the objective

The Investigator candidate shall write an initial investigation report, including an opinion as to the origin and cause of the fire.

EXAMINER'S NOTE

The Investigator candidate will not be allowed to review the performance steps at the time of testing.

PREPARATION & EQUIPMENT

- Investigation findings
- Documentation
- An identified audience
- Forms
- Note pad

Reprinted with permission from NFPA 1033, *Professional Qualifications for Fire Investigator*, Copyright ©2022, National Fire Protection Association, Quincy, MA 02169. This reprinted material is not the complete and official position of the National Fire Protection Association on the referenced subject which is represented only by the standard in its entirety.

TEXAS COMMISSION ON FIRE PROTECTION
Fire Investigator
Performance Standards Evaluation

Candidate: _____

Training Provider: _____

Test Site: _____

Examiner(s): _____

SKILL 23				
Preparing a Written Investigation Report				
Prepare a written report, given investigative findings, documentation, and a specific audience, so that the report accurately reflects the investigative findings, is concise, expresses the investigator's opinion, contains facts and data that the investigator relies on in rendering an opinion, contains the reasoning of the investigator by which each opinion was reached, and meets the needs or requirements of the intended audience(s). (4.7.1)				
The Candidate:	<u>TEST</u>		<u>RETEST</u>	
	S	U	S	U
a) Analyzed the provided investigation information and incident reports				
b) Wrote initial investigation report using provided materials				
c) Included opinion of fire origin				
d) Included opinion of fire cause				
e) Reviewed the report for grammar and accuracy				
f) Verbally expressed the reader's needs or requirements				
g) Performed skill in a safe and proficient manner				

S = Satisfactorily completed/performed

U = Unsatisfactorily performed/failed to meet objective or grading step

All steps of the skill objective are mandatory and must be scored as "Satisfactory" to pass the skill.

Reprinted with permission from NFPA 1033, *Professional Qualifications for Fire Investigator*, Copyright ©2022, National Fire Protection Association, Quincy, MA 02169. This reprinted material is not the complete and official position of the National Fire Protection Association on the referenced subject which is represented only by the standard in its entirety.

TEXAS COMMISSION ON FIRE PROTECTION
Fire Investigator
Performance Standards Evaluation

Examiner/Candidate Comments:

 Certifying Examiner

 Date

Overall Skill Test Score			
Pass:		Fail:	
Overall Skill Re-Test Score			
Pass:		Fail:	

 Re-Test Certifying Examiner

 Date

Reprinted with permission from NFPA 1033, *Professional Qualifications for Fire Investigator*, Copyright ©2022, National Fire Protection Association, Quincy, MA 02169. This reprinted material is not the complete and official position of the National Fire Protection Association on the referenced subject which is represented only by the standard in its entirety.

TEXAS COMMISSION ON FIRE PROTECTION
Fire Investigator
Performance Standards Evaluation

Skill 24

Verbally Expressing Investigative Findings

NFPA 1033, 2022 edition
4.7.2

Presentations

OBJECTIVE

Express investigative findings verbally, given investigative findings, notes, a time allotment, and a specific audience, so that the information is accurate, the presentation is completed within the allotted time, and the presentation includes only need-to-know information for the intended audience. (4.7.2)

INSTRUCTIONS - procedures for achieving the objective

The Investigator candidate shall review and verbally present an investigation report without error to a selected audience.

EXAMINER'S NOTE

The Investigator candidate will not be allowed to review the performance steps at the time of testing.

PREPARATION & EQUIPMENT

- Investigation report findings
- Notes
- An identified audience (i.e., prosecutor, news media, fire chief)

Reprinted with permission from NFPA 1033, *Professional Qualifications for Fire Investigator*, Copyright ©2022, National Fire Protection Association, Quincy, MA 02169. This reprinted material is not the complete and official position of the National Fire Protection Association on the referenced subject which is represented only by the standard in its entirety.

TEXAS COMMISSION ON FIRE PROTECTION
Fire Investigator
Performance Standards Evaluation

Candidate: _____

Training Provider: _____

Test Site: _____

Examiner(s): _____

SKILL 24				
Verbally Expressing Investigative Findings				
Express investigative findings verbally, given investigative findings, notes, a time allotment, and a specific audience, so that the information is accurate, the presentation is completed within the allotted time, and the presentation includes only need-to-know information for the intended audience. (4.7.2)				
	TEST		RETEST	
The Candidate:	S	U	S	U
a) Identified the audience's needs				
b) Verbally presented the report information and correlated findings				
c) Presented only pertinent information for the intended audience				
d) Answered follow-up questions from the audience				
e) Verbalized the impact of releasing information				
f) Performed skill in a safe and proficient manner				

S = Satisfactorily completed/performed

U = Unsatisfactorily performed/failed to meet objective or grading step

All steps of the skill objective are mandatory and must be scored as "Satisfactory" to pass the skill.

Reprinted with permission from NFPA 1033, *Professional Qualifications for Fire Investigator*, Copyright ©2022, National Fire Protection Association, Quincy, MA 02169. This reprinted material is not the complete and official position of the National Fire Protection Association on the referenced subject which is represented only by the standard in its entirety.

TEXAS COMMISSION ON FIRE PROTECTION
Fire Investigator
Performance Standards Evaluation

Examiner/Candidate Comments:

 Certifying Examiner

 Date

 Re-Test Certifying Examiner

 Date

Overall Skill Test Score			
Pass:		Fail:	
Overall Skill Re-Test Score			
Pass:		Fail:	

Reprinted with permission from NFPA 1033, *Professional Qualifications for Fire Investigator*, Copyright ©2022, National Fire Protection Association, Quincy, MA 02169. This reprinted material is not the complete and official position of the National Fire Protection Association on the referenced subject which is represented only by the standard in its entirety.

TEXAS COMMISSION ON FIRE PROTECTION
Fire Investigator
Performance Standards Evaluation

Skill 25
Testifying During Legal Proceedings

NFPA 1033, 2022 edition
4.7.3

Presentations

OBJECTIVE

Testify during legal proceedings, given investigative findings, so that the testimony accurately reflects the facts, data, and scientific principles on which the investigator relied; clearly identifies and expresses the investigator's opinions and conclusions; and contains the reasoning by which each opinion or conclusion was reached. (4.7.3)

INSTRUCTIONS - procedures for achieving the objective

Investigator candidate shall testify and be cross-examined in a mock courtroom.

EXAMINER'S NOTE

The Investigator candidate will not be allowed to review the performance steps at the time of testing.

PREPARATION & EQUIPMENT

- Investigative findings
- 30 minutes to review information
- Consultation with prosecution legal counsel

Reprinted with permission from NFPA 1033, *Professional Qualifications for Fire Investigator*, Copyright ©2022, National Fire Protection Association, Quincy, MA 02169. This reprinted material is not the complete and official position of the National Fire Protection Association on the referenced subject which is represented only by the standard in its entirety.

TEXAS COMMISSION ON FIRE PROTECTION
Fire Investigator
Performance Standards Evaluation

Candidate: _____

Training Provider: _____

Test Site: _____

Examiner(s): _____

SKILL 25				
Testifying During Legal Proceedings				
Testify during legal proceedings, given investigative findings, so that the testimony accurately reflects the facts, data, and scientific principles on which the investigator relied; clearly identifies and expresses the investigator's opinions and conclusions; and contains the reasoning by which each opinion or conclusion was reached. (4.7.3)				
	<u>TEST</u>		<u>RETEST</u>	
The Candidate:	S	U	S	U
a) Reviewed provided information within thirty minutes				
b) Asked questions of the prosecutor before testifying				
c) Answered questions from the prosecutor before testifying				
d) Differentiated between facts and opinions				
e) Testified in court to prosecutor's questions				
f) Testified in court to cross-examination by defense counsel				
g) Demonstrated proper etiquette during proceedings				
h) Performed skill in a safe and proficient manner				

S = Satisfactorily completed/performed

U = Unsatisfactorily performed/failed to meet objective or grading step

All steps of the skill objective are mandatory and must be scored as "Satisfactory" to pass the skill.

Reprinted with permission from NFPA 1033, *Professional Qualifications for Fire Investigator*, Copyright ©2022, National Fire Protection Association, Quincy, MA 02169. This reprinted material is not the complete and official position of the National Fire Protection Association on the referenced subject which is represented only by the standard in its entirety.

TEXAS COMMISSION ON FIRE PROTECTION
Fire Investigator
Performance Standards Evaluation

Examiner/Candidate Comments:

 Certifying Examiner

 Date

 Re-Test Certifying Examiner

 Date

Overall Skill Test Score			
Pass:		Fail:	
Overall Skill Re-Test Score			
Pass:		Fail:	

Reprinted with permission from NFPA 1033, *Professional Qualifications for Fire Investigator*, Copyright ©2022, National Fire Protection Association, Quincy, MA 02169. This reprinted material is not the complete and official position of the National Fire Protection Association on the referenced subject which is represented only by the standard in its entirety.

END OF PERFORMANCE SKILLS

THIS PAGE INTENTIONALLY LEFT BLANK
